

Karakteristike

Priključak 1	metrički vanjski navoji, cilindrični
Oblik brtve 1	24° unutarnji konus
Priključak 2	metrički vanjski navoji, cilindrični
Oblik brtve 2	24° unutarnji konus
Izvedba	Pregradni vijčani spoj za zavarivanje
Oblik izrade	ravno
Norma	DIN 2353 ISO 8434-1
Opseg isporuke	Nastavak (bez preturme matice i nareznog prstena)
Materijal	Čelik
Površinska zaštita	fosfatirana i nauljena (Znphr5f)

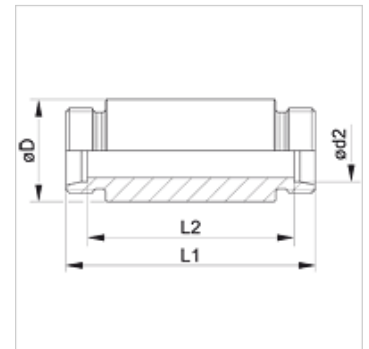

Napomena

Upute za montažu, ugradnju, tlačno opterećenje i dopuštene radne temperature pronaći ćete u tehničkim informacijama za vijčane spojeve cijevi.

Artikli

Naziv	Seriya	Radni tlak bari	Ø d2 (mm)	Ø D (mm)	L1 (mm)	L2 (mm)
XSE NW 04 HL	L	PN 315	6	18,0	70	56
XSE NW 06 HL	L	PN 315	8	20,0	70	56
XSE NW 08 HL	L	PN 315	10	22,0	72	58
XSE NW 10 HL	L	PN 315	12	25,0	72	58
XSE NW 13 HL	L	PN 315	15	28,0	84	70
XSE NW 16 HL	L	PN 315	18	32,0	84	69
XSE NW 20 HL	L	PN 160	22	36,0	88	73
XSE NW 25 HL	L	PN 160	28	40,0	88	73
XSE NW 32 HL	L	PN 160	35	50,0	92	71
XSE NW 40 HL	L	PN 160	42	60,0	92	70
XSE NW 03 HS	S	PN 630	6	20,0	74	60
XSE NW 04 HS	S	PN 630	8	22,0	74	60
XSE NW 06 HS	S	PN 630	10	25,0	74	59
XSE NW 08 HS	S	PN 630	12	28,0	74	59
XSE NW 10 HS	S	PN 630	14	30,0	88	72
XSE NW 13 HS	S	PN 400	16	35,0	88	71
XSE NW 16 HS	S	PN 400	20	38,0	92	71
XSE NW 20 HS	S	PN 400	25	45,0	96	72
XSE NW 25 HS	S	PN 400	30	50,0	100	73
XSE NW 32 HS	S	PN 315	38	60,0	104	72

Seriya: LL = veoma lagan L = lagan S = težak – PN = nazivni tlak PB = maks. radni tlak – Ø d2 = vanjski promjer cijevi

Varijante proizvoda

XSE VA	Pregradni vijčani spoj za zavarivanje, Oplemenjeni čelik
SE	Pregradni vijčani spoj za zavarivanje, Čelik