

Karakteristike

Priključak 1	metrički vanjski navoji, cilindrični
Oblik brtve 1	Profil E
Priključak 2	metrički vanjski navoji, cilindrični
Oblik brtve 2	24° unutarnji konus
Izvedba	Uvrtni vijčani spoj
Oblik izrade	ravno
Norma	DIN 3901
Opseg isporuke	Nastavak (bez preturane matice i nareznog prstena)
Materijal	Oplemenjeni čelik

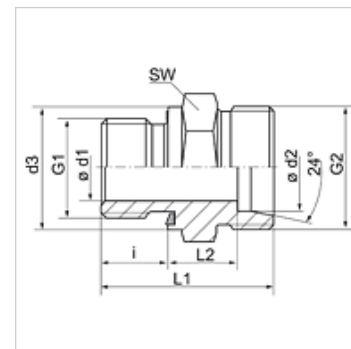

Napomena

Upute za montažu, ugradnju, tlačno opterećenje i dopuštene radne temperature pronaći ćete u tehničkim informacijama za vijčane spojeve cijevi.

Napomene uz narudžbu

Ulošci NBR ulošci brtve

FPM (Viton) na zahtjev

Artikli

Naziv	Serijska	Radni tlak bari	Ø d2 (mm)	G1	G2	Ø d3 (mm)	i (mm)	L1 (mm)	L2 (mm)	SW (mm)
XVM NW 04 HL ED VA	L	PN 315	6	M 10 x 1	M 12 x 1,5	14,0	8	23,5	8,5	14
XVM NW 04 HL 12 ED VA	L	PN 315	6	M 12 x 1,5	M 12 x 1,5	17,0	12	23,5	8,5	17
XVM NW 04 HL 14 ED VA	L	PN 315	6	M 14 x 1,5	M 12 x 1,5	19,0	12	27,0	10,0	14
XVM NW 06 HL ED VA	L	PN 315	8	M 12 x 1,5	M 14 x 1,5	12,0	12	29,0	10,0	17
XVM NW 06 HL 10 ED VA	L	PN 315	8	M 10 x 1	M 14 x 1,5	14,0	8	26,0	9,5	17
XVM NW 06 HL 14 ED VA	L	PN 315	8	M 14 x 1,5	M 14 x 1,5	19,0	12	27,0	10,0	19
XVM NW 06 HL 16 ED VA	L	PN 315	8	M 16 x 1,5	M 14 x 1,5	22,0	12	25,0	10,0	22
XVM NW 06 HL 18 ED VA	L	PN 315	8	M 18 x 1,5	M 14 x 1,5	24,0	12	25,0	10,0	24
XVM NW 08 HL ED VA	L	PN 315	10	M 14 x 1,5	M 16 x 1,5	19,0	12	30,0	11,0	19
XVM NW 08 HL 10 ED VA	L	PN 315	10	M 10 x 1	M 16 x 1,5	14,0	8	27,5	11,0	17
XVM NW 08 HL 12 ED VA	L	PN 315	10	M 12 x 1,5	M 16 x 1,5	17,0	12	30,0	11,0	17
XVM NW 08 HL 16 ED VA	L	PN 315	10	M 16 x 1,5	M 16 x 1,5	22,0	12	31,5	12,5	22
XVM NW 08 HL 18 ED VA	L	PN 315	10	M 18 x 1,5	M 16 x 1,5	24,0	12	31,5	12,5	24
XVM NW 08 HL 22 ED VA	L	PN 315	10	M 22 x 1,5	M 16 x 1,5	27,0	14	35,0	14,0	27
XVM NW 10 HL ED VA	L	PN 315	12	M 16 x 1,5	M 18 x 1,5	22,0	12	31,5	12,5	22
XVM NW 10 HL 12 ED VA	L	PN 315	12	M 12 x 1,5	M 18 x 1,5	17,0	12	28,0	13,0	19
XVM NW 10 HL 14 ED VA	L	PN 315	12	M 14 x 1,5	M 18 x 1,5	19,0	12	30,0	11,0	19
XVM NW 10 HL 18 ED VA	L	PN 315	12	M 18 x 1,5	M 18 x 1,5	24,0	12	31,5	12,5	24
XVM NW 10 HL 22 ED VA	L	PN 315	12	M 22 x 1,5	M 18 x 1,5	27,0	14	35,0	14,0	27
XVM NW 13 HL ED VA	L	PN 315	15	M 18 x 1,5	M 22 x 1,5	24,0	12	32,5	13,5	24
XVM NW 13 HL 16 ED VA	L	PN 315	15	M 16 x 1,5	M 22 x 1,5	22,0	12	32,0	13,0	24
XVM NW 13 HL 22 ED VA	L	PN 315	15	M 22 x 1,5	M 22 x 1,5	27,0	14	36,0	15,0	27
XVM NW 16 HL ED VA	L	PN 315	18	M 22 x 1,5	M 26 x 1,5	27,0	14	36,0	14,5	27
XVM NW 16 HL 18 ED VA	L	PN 315	18	M 18 x 1,5	M 26 x 1,5	24,0	12	33,5	14,0	27
XVM NW 20 HL ED VA	L	PN 160	22	M 26 x 1,5	M 30 x 2	32,0	16	40,0	16,5	32
XVM NW 25 HL ED VA	L	PN 160	28	M 33 x 2	M 36 x 2	40,0	18	43,0	17,5	41
XVM NW 32 HL ED VA	L	PN 160	35	M 42 x 2	M 45 x 2	50,0	20	48,0	17,5	50
XVM NW 40 HL ED VA	L	PN 160	42	M 48 x 2	M 52 x 2	55,0	22	55,0	19,0	55
XVM NW 03 HS ED VA	S	PN 630	6	M 12 x 1,5	M 14 x 1,5	17,0	12	32,0	13,0	17
XVM NW 03 HS 14 ED VA	S	PN 630	6	M 14 x 1,5	M 14 x 1,5	19,0	12	30,0	15,0	19
XVM NW 04 HS ED VA	S	PN 630	8	M 14 x 1,5	M 16 x 1,5	19,0	12	34,0	15,0	19
XVM NW 06 HS ED VA	S	PN 630	10	M 16 x 1,5	M 18 x 1,5	22,0	12	34,5	15,0	22
XVM NW 08 HS ED VA	S	PN 630	12	M 18 x 1,5	M 20 x 1,5	24,0	12	36,5	17,0	24
XVM NW 08 HS 14 ED VA	S	PN 630	12	M 14 x 1,5	M 20 x 1,5	19,0	12	33,0	16,0	22
XVM NW 10 HS ED VA	S	PN 630	14	M 20 x 1,5	M 22 x 1,5	26,0	14	41,0	19,0	27
XVM NW 13 HS ED VA	S	PN 400	16	M 22 x 1,5	M 24 x 1,5	27,0	14	41,0	18,5	27
XVM NW 13 HS 18 ED VA	S	PN 400	16	M 18 x 1,5	M 24 x 1,5	24,0	12	38,5	18,0	27
XVM NW 16 HS ED VA	S	PN 400	20	M 27 x 2	M 30 x 2	32,0	16	47,0	20,5	32
XVM NW 20 HS ED VA	S	PN 400	25	M 33 x 2	M 36 x 2	40,0	18	53,0	23,0	41



Artikli

Naziv	Serija	Radni tlak bari	Ø d2 (mm)	G1	G2	Ø d3 (mm)	i (mm)	L1 (mm)	L2 (mm)	SW (mm)
XVM NW 25 HS ED VA	S	PN 400	30	M 42 x 2	M 42 x 2	50,0	20	57,0	23,5	50
XVM NW 32 HS ED VA	S	PN 315	38	M 48 x 2	M 52 x 2	55,0	22	64,0	26,0	55

Serija: LL = veoma lagan L = lagan S = težak - PN = nazivni tlak PB = maks. radni tlak - Ø d2 = vanjski promjer cijevi

Varijante proizvoda

XVM ED Uvrtni vijčani spoj, Čelik

VM VA Uvrtni vijčani spoj, Oplemenjeni čelik

Rezervni dijelovi

WD V Meka brtva JIC