

Karakteristike

Priključak 1	BSP vanjski navoj, konusni
Oblik brtve 1	brtvljenje navoja
Priključak 2	metrički vanjski navoji, cilindrični
Oblik brtve 2	24° unutarnji konus
Izvedba	Uvrtni vijčani spoj
Oblik izrade	ravno
Norma	DIN 2353 ISO 8434-1
Opseg isporuke	Nastavak (bez pretorne matice i nareznog prstena)
Materijal	Čelik
Površinska zaštita	galvanski premaz

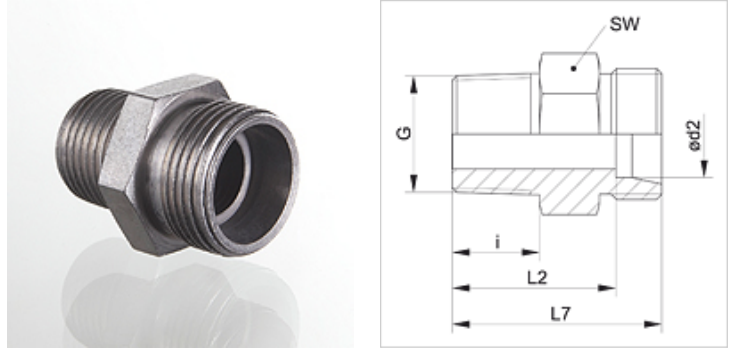

Napomena

Upute za montažu, ugradnju, tlačno opterećenje i dopuštene radne temperature pronaći ćete u tehničkim informacijama za vijčane spojeve cijevi.

Artikli

Naziv	Seriya	Radni tlak bari	Ø d2 (mm)	G	i (mm)	L2 (mm)	L7 (mm)	SW (mm)
XVR 04 LL	LL	PN 100	4	R 1/8" K	8,0	16,0	20,0	11
XVR 05 LL	LL	PN 100	5	R 1/8" K	8,0	14,5	20,0	11
XVR 06 LL	LL	PN 100	6	R 1/8" K	8,0	14,5	20,0	11
XVR 06 LL 1/4	LL	PN 100	6	R 1/4" K	12,0	14,5	20,0	12
XVR 08 LL	LL	PN 100	8	R 1/8" K	8,0	16,5	22,0	12
XVR 08 LL 1/4	LL	PN 100	8	R 1/4" K	12,0	20,5	26,0	14
XVR 10 LL	LL	PN 100	10	R 1/4" K	12,0	20,5	26,0	14
XVR 12 LL	LL	PN 100	12	R 1/4" K	12,0	20,0	26,0	17
XVR 12 LL 3/8	LL	PN 100	12	R 3/8" K	12,0	20,0	26,0	17
XVRK NW 04 HL	L	PN 315	6	R 1/8" K	10,5	17,5	24,5	12
XVRK NW 04 HL 1/4	L	PN 315	6	R 1/4" K	14,0	22,0	29,0	17
XVRK NW 06 HL 1/8	L	PN 315	8	R 1/8" K	10,5	18,5	25,5	14
XVRK NW 06 HL	L	PN 315	8	R 1/4" K	14,0	22,0	29,0	17
XVRK NW 06 HL 3/8	L	PN 315	8	R 3/8" K	14,5	22,5	30,5	19
XVRK NW 06 HL 1/2	L	PN 315	8	R 1/2" K	18,5	27,5	34,5	22
XVRK NW 08 HL 1/8	L	PN 315	10	R 1/8" K	10,5	19,5	26,5	17
XVRK NW 08 HL	L	PN 315	10	R 1/4" K	14,0	23,0	30,0	17
XVRK NW 08 HL 3/8	L	PN 315	10	R 3/8" K	14,5	24,5	31,5	19
XVRK NW 08 HL 1/2	L	PN 315	10	R 1/2" K	18,5	28,5	35,5	22
XVRK NW 10 HL 1/4	L	PN 315	12	R 1/4" K	14,0	24,0	31,0	19
XVRK NW 10 HL	L	PN 315	12	R 3/8" K	14,5	24,5	31,5	19
XVRK NW 10 HL 1/2	L	PN 315	12	R 1/2" K	18,5	28,5	35,5	24
XVRK NW 13 HL 3/8	L	PN 315	15	R 3/8" K	14,5	25,5	24,0	33
XVRK NW 13 HL	L	PN 315	15	R 1/2" K	18,5	29,5	36,5	24
XVRK NW 16 HL 3/8	L	PN 315	18	R 3/8" K	14,5	26,0	33,5	27
XVRK NW 16 HL	L	PN 315	18	R 1/2" K	18,5	30,0	37,5	27
XVRK NW 16 HL 3/4	L	PN 160	18	R 3/4" K	20,0	31,5	39,0	32
XVRK NW 20 HL 1/2	L	PN 160	22	R 1/2" K	18,5	32,0	39,5	32
XVRK NW 20 HL	L	PN 160	22	R 3/4" K	20,0	33,5	41,0	32
XVRK NW 25 HL	L	PN 160	28	R 1" K	24,0	38,5	46,0	41
XVRK NW 32 HL 1	L	PN 160	35	R 1" K	24,0	40,5	51,0	46
XVRK NW 32 HL	L	PN 160	35	R 1,1/4" K	26,0	42,5	53,0	46
XVRK NW 40 HL	L	PN 160	42	R 1,1/2" K	27,0	43,0	54,0	55
XVRK NW 03 HS	S	PN 400	6	R 1/4" K	14,0	27,0	34,0	17
XVRK NW 04 HS	S	PN 400	8	R 1/4" K	14,0	27,0	34,0	17
XVRK NW 06 HS 1/4	S	PN 400	10	R 1/4" K	14,0	26,5	34,0	19
XVRK NW 06 HS	S	PN 400	10	R 3/8" K	14,5	27,0	34,5	19
XVRK NW 08 HS 1/4	S	PN 400	12	R 1/4" K	14,0	28,5	36,0	22
XVRK NW 08 HS	S	PN 400	12	R 3/8" K	14,5	29,0	36,5	22
XVRK NW 08 HS 1/2	S	PN 400	12	R 1/2" K	18,5	33,0	40,5	22
XVRK NW 10 HS 3/8	S	PN 400	14	R 3/8" K	14,5	30,5	38,5	24



Artikli

Naziv	Seriya	Radni tlak bari	Ø d2 (mm)	G	i (mm)	L2 (mm)	L7 (mm)	SW (mm)
XVRK NW 10 HS	S	PN 400	14	R 1/2" K	18,5	34,5	42,5	24
XVRK NW 13 HS 3/8	S	PN 400	16	R 3/8" K	14,5	30,0	38,5	27
XVRK NW 13 HS	S	PN 400	16	R 1/2" K	18,5	34,0	42,5	27
XVRK NW 16 HS	S	PN 400	20	R 3/4" K	20,0	37,5	48,0	32
XVRK NW 20 HS	S	PN 400	25	R 1" K	24,0	43,0	55,0	41
XVRK NW 25 HS 1	S	PN 400	30	R 1" K	24,0	43,5	57,0	46
XVRK NW 25 HS	S	PN 400	30	R 1,1/4" K	26,0	45,5	59,0	46
XVRK NW 32 HS	S	PN 315	38	R 1,1/2" K	27,0	49,0	65,0	55

Seriya: LL = veoma lagan L = lagan S = težak - PN = nazivni tlak PB = maks. radni tlak - Ø d2 = vanjski promjer cijevi

Varijante proizvoda

XVRK VA	Uvrtni vijčani spoj, Oplemenjeni čelik
VRK	Uvrtni vijčani spoj, Čelik