

W45 AN HN

Uvrtni nastavak, kut 45°

Karakteristike

Priključak 1	NPT navoji matice (NPSM)
Oblik brtve 1	60° vanjski konus
Priključak 2	NPT vanjski navoji
Oblik brtve 2	brtvljenje navoja
Izvedba	Uvrtni nastavci
Oblik izrade	Kutevi 45°
Materijal	Čelik
Površinska zaštita	galvanski premaz

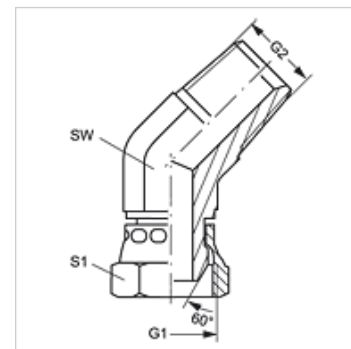

Artikli

Naziv	G1	G2	SW (mm)	S1
W45 AN 02 HN	1/8" -27 NPT	1/8" -27 NPT	11	14
W45 AN 04 HN	1/4" - 18 NPT	1/4" - 18 NPT	14	18
W45 AN 06 HN	3/8" - 18 NPT	3/8" - 18 NPT	19	22
W45 AN 06 HN 08	3/8" - 18 NPT	1/2" - 14 NPT	22	22
W45 AN 08 HN	1/2" - 14 NPT	1/2" - 14 NPT	22	25
W45 AN 08 HN 12	1/2" - 14 NPT	3/4" - 14 NPT	27	25
W45 AN 12 HN	3/4" - 14 NPT	3/4" - 14 NPT	27	32
W45 AN 12 HN 16	3/4" - 14 NPT	1" -11,5 NPT	33	32
W45 AN 16 HN 12	1" -11,5 NPT	3/4" - 14 NPT	33	38
W45 AN 16 HN	1" -11,5 NPT	1" -11,5 NPT	33	38
W45 AN 20 HN	1,1/4" - 11,5 NPT	1,1/4" - 11,5 NPT	41	48
W45 AN 24 HN	1,1/2" - 11,5 NPT	1,1/2" - 11,5 NPT	48	54
W45 AN 32 HN	2" -11,5 NPT	2" -11,5 NPT	64	67

SW, S1, S2 = širina klučca