

# W45 HN HJOF

Uvrtni nastavak, kut 45°

## Karakteristike

Priključak 1	NPT vanjski navoji
Oblik brtve 1	brtvljenje navoja
Priključak 2	ORFS vanjski navoji
Oblik brtve 2	brtvljenje površina s O-prstenom
Izvedba	Uvrtni nastavci
Oblik izrade	ravno
Materijal	Čelik
Površinska zaštita	galvanski premaz

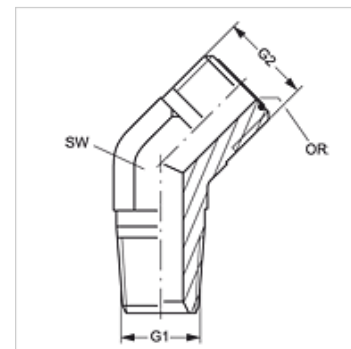

## Artikli

Naziv	G1	G2	SW (mm)	OR
W45 HN 02 HJOF 04	1/8" -27 NPT	9/16" - 18 UNF	14	7,65 x 1,78
W45 HN 04 HJOF	1/4" - 18 NPT	9/16" - 18 UNF	14	7,65 x 1,78
W45 HN 04 HJOF 06	1/4" - 18 NPT	11/16" - 16 UN	19	9,25 x 1,78
W45 HN 06 HJOF 04	3/8" - 18 NPT	9/16" - 18 UNF	19	7,65 x 1,78
W45 HN 06 HJOF	3/8" - 18 NPT	11/16" - 16 UN	19	9,25 x 1,78
W45 HN 06 HJOF 08	3/8" - 18 NPT	13/16" - 16 UN	19	12,42 x 1,78
W45 HN 08 HJOF 06	1/2" - 14 NPT	11/16" - 16 UN	22	9,25 x 1,78
W45 HN 08 HJOF	1/2" - 14 NPT	13/16" - 16 UN	22	12,42 x 1,78
W45 HN 08 HJOF 10	1/2" - 14 NPT	1" -14 UNS	27	15,60 x 1,78
W45 HN 12 HJOF	3/4" - 14 NPT	1,3/16" -12 UN	30	18,77 x 1,78
W45 HN 16 HJOF	1" -11,5 NPT	1,7/16" -12 UN	37	23,52 x 1,78

SW = širina ključa