

W45 HRK IR

Uvrtni nastavak, kut 45°

Karakteristike

Priključak 1	BSP vanjski navoj, konusni
Oblik brtve 1	brtvljenje navoja
Priključak 2	BSP unutarnji navoj, cilindrični
Oblik brtve 2	plosnato brtvljenje
Izvedba	Uvrtni nastavci
Oblik izrade	Kutevi 45°
Materijal	Čelik
Površinska zaštita	galvanski premaz

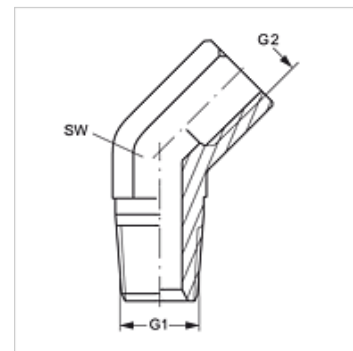

Artikli

Naziv	G1	G2	SW (mm)
W45 HRK 02 IR	R 1/8" K	G 1/8" - 28	14
W45 HRK 04 IR	R 1/4" K	G 1/4" - 19	19
W45 HRK 06 IR	R 3/8" K	G 3/8" - 19	22
W45 HRK 08 IR	R 1/2" K	G 1/2" -14	27
W45 HRK 12 IR	R 3/4" K	G 3/4" -14	32
W45 HRK 16 IR	R 1" K	G 1" -11	41

SW = širina ključa