

W45 O AN

Uvrtni nastavak, kut 45°

Karakteristike

Priključak 1	UN/UNF vanjski navoji
Oblik brtve 1	O prstenasta brtva na uvrtnom nastavku
Priključak 2	NPSM navoji matice
Oblik brtve 2	60° vanjski konus
Izvedba	Uvrtni nastavak, podesiv po smjeru
Oblik izrade	Kutevi 45°
Materijal	Čelik
Površinska zaštita	galvanski premaz

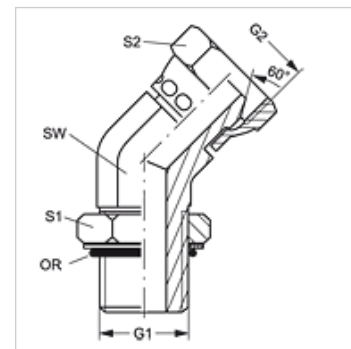

Artikli

Naziv	G1	G2	SW (mm)	S1	S2	OR
W45 O 04 AN	7/16" -20 UNF	1/4" - 18 NPT	11	14	18	8,92 x 1,83
W45 O 06 AN 04	9/16" - 18 UNF	1/4" - 18 NPT	14	22	14	11,90 x 1,98
W45 O 06 AN	9/16" - 18 UNF	3/8" - 18 NPT	14	18	22	11,90 x 1,98
W45 O 08 AN 06	3/4" - 16 UNF	3/8" - 18 NPT	19	22	22	16,36 x 2,20
W45 O 08 AN	3/4" - 16 UNF	1/2" - 14 NPT	19	22	25	16,36 x 2,20
W45 O 08 AN 12	3/4" - 16 UNF	3/4" - 14 NPT	19	22	32	16,36 x 2,20
W45 O 10 AN 08	7/8" -14 UNF	1/2" - 14 NPT	22	25	25	19,18 x 2,46
W45 O 12 AN	1.1/16" -12 UN	3/4" - 14 NPT	27	32	32	23,47 x 2,95

SW, S1, S2 = širina klučca