

# W90 IR HJ

Spojni nastavak, IGR AGJ kut 90°

**HANSA FLEX**

## Karakteristike

Priključak 1	BSP unutarnji navoj, cilindrični
Oblik brtve 1	plosnato brtvljenje
Priključak 2	UN/UNF vanjski navoji
Oblik brtve 2	74° vanjski konus
Izvedba	Spojni nastavci
Oblik izrade	Kutevi 90°
Materijal	Čelik
Površinska zaštita	galvanski premaz

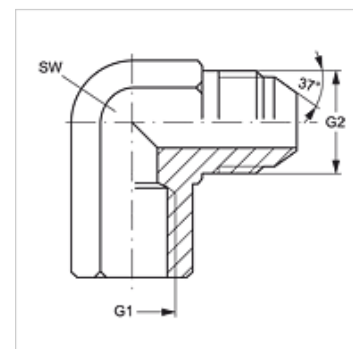

## Artikli

Naziv	G1	G2	SW (mm)
W90 IR 02 HJ 04	G 1/8" - 28	7/16" -20 UNF	14
W90 IR 02 HJ 05	G 1/8" - 28	1/2" -20 UNF	14
W90 IR 04 HJ	G 1/4" - 19	7/16" -20 UNF	19
W90 IR 04 HJ 05	G 1/4" - 19	1/2" -20 UNF	19
W90 IR 04 HJ 06	G 1/4" - 19	9/16" - 18 UNF	19
W90 IR 04 HJ 08	G 1/4" - 19	3/4" - 16 UNF	19
W90 IR 06 HJ	G 3/8" - 19	9/16" - 18 UNF	22
W90 IR 06 HJ 08	G 3/8" - 19	3/4" - 16 UNF	22
W90 IR 08 HJ	G 1/2" -14	3/4" - 16 UNF	27
W90 IR 08 HJ 10	G 1/2" -14	7/8" - 14 UNF	27
W90 IR 08 HJ 12	G 1/2" -14	1.1/16" -12 UN	27
W90 IR 12 HJ	G 3/4" -14	1.1/16" -12 UN	33
W90 IR 16 HJ	G 1" -11	1,5/16" -12 UN	41
W90 IR 16 HJ 20	G 1" -11	1,5/8" -12 UN	48
W90 IR 20 HJ	G 1,1/4" - 11	1,5/8" -12 UN	48

SW = širina ključa