

# BZL / BZS MG

Čep bez preturzne matice

## Karakteristike

Oblik brtve 1 24° vanjski konus s O prstenom

Izvedba Čep bez preturzne matice

Oblik izrade ravno

Norma DIN 2353  
ISO 8434-1

Materijal Mjed

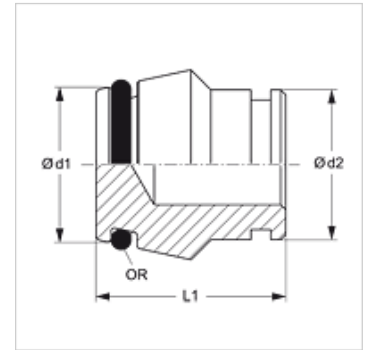

## Napomena

Upute za montažu, ugradnju, tlačno opterećenje i dopuštene radne temperature pronaći ćete u tehničkim informacijama za vijčane spojeve cijevi.

## Artikli

Naziv	Seriya	Radni tlak bari	Ø d1 (mm)	Ø d2 (mm)	L1 (mm)	OR
BZL NW 04 MG	L	PN 200	6,6	6	18,5	4,0 x 1,5
BZL NW 06 MG	L	PN 200	8,5	8	18,0	6,0 x 1,5
BZL NW 08 MG	L	PN 200	10,6	10	19,5	7,5 x 1,5
BZL NW 10 MG	L	PN 200	12,6	12	19,0	9,0 x 1,5
BZL NW 13 MG	L	PN 200	15,5	15	19,0	12,0 x 2,0
BZL NW 16 MG	L	PN 200	18,6	18	22,0	15,0 x 2,0
BZL NW 20 MG	L	PN 100	22,6	22	22,0	20,0 x 2,0
BZL NW 25 MG	L	PN 100	28,5	28	23,5	26,0 x 2,0
BZS NW 10 MG	S	PN 400	14,5	14	21,0	10,0 x 2,0
BZS NW 13 MG	S	PN 250	16,5	16	22,0	12,0 x 2,0
BZS NW 16 MG	S	PN 250	20,9	20	26,5	16,3 x 2,4
BZS NW 20 MG	S	PN 250	25,9	25	27,5	20,3 x 2,4

Seriya: LL = veoma lagan L = lagan S = težak - PN = nazivni tlak PB = maks. radni tlak - Ø = vanjski promjer cijevi

## Varijante proizvoda

BZL / BZS Čep bez preturzne matice, Čelik

BZL VA / BZS VA Čep bez preturzne matice, Oplemenjeni čelik