

# FHR 90

Čep s navojem, imbus

**HANSA FLEX**

## Karakteristike

Priključak 1	BSP vanjski navoj, cilindrični
Oblik brtve 1	Profil A
Izvedba	Čep s navojem, imbus
Oblik izrade	ravno
Norma	DIN 908
Materijal	Čelik
Površinska zaštita	galvanski premaz

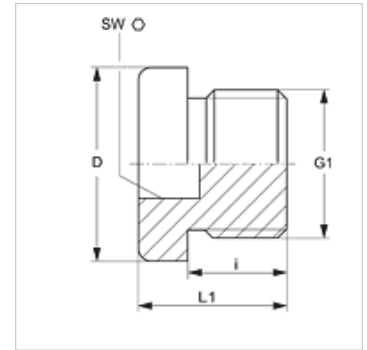

## Artikli

Naziv	G1	D (mm)	i (mm)	L1 (mm)	SW (mm)
FHR 90-1/8	G 1/8" - 28	14	8	11	5
FHR 90-1/4	G 1/4" - 19	18	12	15	6
FHR 90-3/8	G 3/8" - 19	22	12	15	8
FHR 90-1/2	G 1/2" - 14	26	14	18	10
FHR 90-5/8	G 5/8" - 14	28	14	18	12
FHR 90-3/4	G 3/4" - 14	32	16	20	12
FHR 90-1	G 1" - 11	39	16	21	17
FHR 90-1 1/4	G 1,1/4" - 11	49	16	21	22
FHR 90-1 1/2	G 1,1/2" - 11	55	16	21	24
FHR 90-2	G 2" - 11	68	20	25	32

PN = nazivni tlak PB = maks. radni tlak