

Karakteristike

Priključak 1 + 2	metrički vanjski navoji, cilindrični
Oblik brtve 1 + 2	24° unutarnji konus
Izvedba	Pregradni vijčani spoj
Oblik izrade	Kutevi 90°
Norma	DIN 2353 ISO 8434-1
Opseg isporuke	Nastavak (bez preturane matice i nareznog prstena)
Materijal	Čelik
Površinska zaštita	galvanski premaz

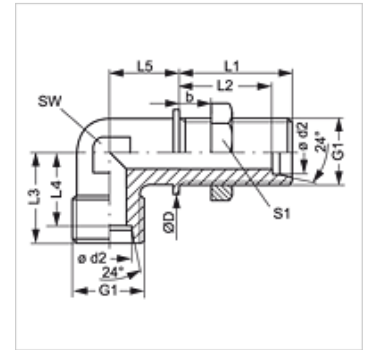

Napomena

Upute za montažu, ugradnju, tlačno opterećenje i dopuštene radne temperature pronaći ćete u tehničkim informacijama za vijčane spojeve cijevi.

Artikli

Naziv	Seriya	Radni tlak bari	Ø d2 (mm)	G1	Ø D (mm)	b (mm)	L1 (mm)	L2 (mm)	L3 (mm)	L4 (mm)	L5 (mm)	SW (mm)	S1
XSW NW 04 HL	L	PN 315	6	M 12 x 1,5	17	16	34	27,0	19	12,0	14	12	17
XSW NW 06 HL	L	PN 315	8	M 14 x 1,5	19	16	34	27,0	21	14,0	17	12	19
XSW NW 08 HL	L	PN 315	10	M 16 x 1,5	22	16	35	28,0	22	15,0	18	14	22
XSW NW 10 HL	L	PN 315	12	M 18 x 1,5	24	16	36	29,0	24	17,0	20	17	24
XSW NW 13 HL	L	PN 315	15	M 22 x 1,5	27	16	38	31,0	28	21,0	23	19	30
XSW NW 16 HL	L	PN 315	18	M 26 x 1,5	32	16	40	32,5	31	23,5	24	24	36
XSW NW 20 HL	L	PN 160	22	M 30 x 2	36	16	42	34,5	35	27,5	30	27	41
XSW NW 25 HL	L	PN 160	28	M 36 x 2	42	16	43	35,5	38	30,5	34	36	46
XSW NW 32 HL	L	PN 160	35	M 45 x 2	50	16	47	36,5	45	34,5	39	41	55
XSW NW 40 HL	L	PN 160	42	M 52 x 2	60	16	47	36,0	51	40,0	43	50	65
XSW NW 03 HS	S	PN 630	6	M 14 x 1,5	19	16	36	29,0	23	16,0	17	12	19
XSW NW 04 HS	S	PN 630	8	M 16 x 1,5	22	16	36	29,0	24	17,0	18	14	22
XSW NW 06 HS	S	PN 630	10	M 18 x 1,5	24	16	36	29,5	25	17,5	20	17	24
XSW NW 08 HS	S	PN 630	12	M 20 x 1,5	27	16	38	30,5	29	21,5	21	17	27
XSW NW 10 HS	S	PN 630	14	M 22 x 1,5	27	16	40	32,0	30	22,0	23	19	30
XSW NW 13 HS	S	PN 400	16	M 24 x 1,5	30	16	40	31,5	33	24,5	24	24	32
XSW NW 16 HS	S	PN 400	20	M 30 x 2	36	16	44	33,5	37	26,5	30	27	41
XSW NW 20 HS	S	PN 400	25	M 36 x 2	42	16	47	35,0	42	30,0	34	36	46
XSW NW 25 HS	S	PN 400	30	M 42 x 2	50	16	51	37,5	49	35,5	39	41	50
XSW NW 32 HS	S	PN 315	38	M 52 x 2	60	16	53	37,0	57	41,0	43	50	65

Seriya: LL = veoma lagan L = lagan S = težak - PN = nazivni tlak PB = maks. radni tlak - Ø d2 = vanjski promjer cijevi

Varijante proizvoda

XSW VA	Pregradni vijčani spoj, kut 90°, Oplemenjeni čelik
SW	Pregradni vijčani spoj, kut 90°, Čelik