

Karakteristike

Primjena Vodovi za rashladno sredstvo i maziva za obradu metala pri uklanjanju srhova.

Izvedba Čelična nosiva spirala od PVC unutarnjeg crijeva s obje strane uvrtni nastavci od čelika
Površina poniklana

Karakteristike Potpuno nepropusno
rukom se može saviti u gotovo svaki položaj
stabilno
otporno na ulje, masti itd.

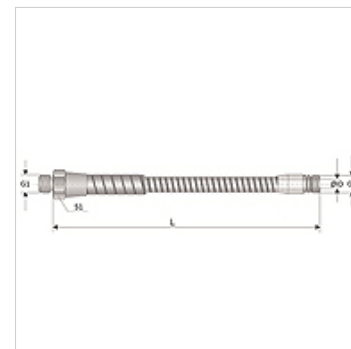

Napomene uz narudžbu

Ostale dimenzije na zahtjev

Artikli

Naziv	G1	G2	ID (mm)	S1 (mm)	Nazivna duljina (+/-5 mm)
UPG G1/8-250	R 1/8"	R 1/8"	8,0	15,0	250
UPG G1/8-320	R 1/8"	R 1/8"	8,0	15,0	320
UPG G1/8-400	R 1/8"	R 1/8"	8,0	15,0	400
UPG G1/8-500	R 1/8"	R 1/8"	8,0	15,0	500
UPG G1/4-200	R 1/4"	R 1/4"	10,0	19,0	200
UPG G1/4-250	R 1/4"	R 1/4"	10,0	19,0	250
UPG G1/4-320	R 1/4"	R 1/4"	10,0	19,0	320
UPG G1/4-400	R 1/4"	R 1/4"	10,0	19,0	400
UPG G1/4-500	R 1/4"	R 1/4"	10,0	19,0	500
UPG G1/4-630	R 1/4"	R 1/4"	10,0	19,0	630
UPG G1/4-800	R 1/4"	R 1/4"	10,0	19,0	800
UPG G3/8-200	R 3/8"	R 3/8"	10,0	24,0	200
UPG G3/8-320	R 3/8"	R 3/8"	10,0	24,0	320
UPG G3/8-400	R 3/8"	R 3/8"	10,0	24,0	400
UPG G3/8-500	R 3/8"	R 3/8"	10,0	24,0	500
UPG G3/8-630	R 3/8"	R 3/8"	10,0	24,0	630
UPG G3/8-800	R 3/8"	R 3/8"	10,0	24,0	800
UPG G1/2-500	R 1/2"	R 1/2"	10,0	27,0	500
UPG G1/2-630	R 1/2"	R 1/2"	10,0	27,0	630
UPG G1/2-800	R 1/2"	R 1/2"	10,0	27,0	800