

T IN HN

Navrtni nastavak, T oblik

HANSA FLEX

Karakteristike

Priključak 1 NPT unutarnji navoj

Oblik brtve 1 brtvljenje navoja

Priključak 2 + 3 NPT vanjski navoji

Oblik brtve 2 + 3 brtvljenje navoja

Izvedba Uvrtni nastavci

Oblik izrade T oblik

Materijal Čelik

Površinska zaštita galvanski premaz

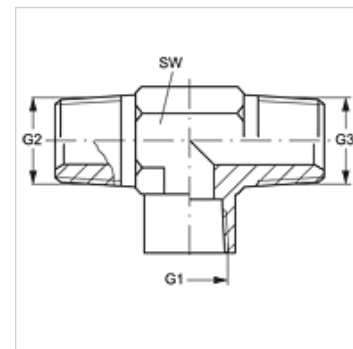

Artikli

Naziv	G1	G2 + G3	SW (mm)
T IN 02 HN	1/8" -27 NPT	1/8" -27 NPT	14
T IN 04 HN	1/4" - 18 NPT	1/4" - 18 NPT	19
T IN 06 HN	3/8" - 18 NPT	3/8" - 18 NPT	22
T IN 08 HN	1/2" - 14 NPT	1/2" - 14 NPT	27
T IN 12 HN	3/4" - 14 NPT	3/4" - 14 NPT	33
T IN 16 HN	1" -11,5 NPT	1" -11,5 NPT	41
T IN 20 HN	1,1/4" - 11,5 NPT	1,1/4" - 11,5 NPT	48

SW = širina ključa