

HK CSTS C

Zglobna glava s ležajem s naknadnim podmazivanjem

HANSA FLEX

Karakteristike

Norma DIN 648, SERIJA E. TIP C

Područje primjene Industrija

Materijal Čelik ST 52.3

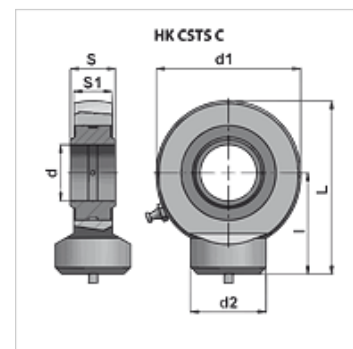

Napomena

HKCSTS012C00 se ne može naknadno podmazati

HKCSTS015C00, HKCSTS016C00, HKCSTS017C00 mogu se naknadno podmazivati samo preko rupe za podmazivanje (nema nazuvice za podmazivanje)

Artikli

Naziv	d (mm)	d1 (mm)	d2 (mm)	l (mm)	L (mm)	S1 (mm)	S (mm)	dopušteno din. opterećenje (kN)	Težina (kg)
HK CSTS 012 C 00	12	34	16,0	27	44,0	8	10	10	0,06
HK CSTS 015 C 00	15	40	20,0	31	51,0	10	12	17	0,12
HK CSTS 016 C 00	16	46	21,5	35	58,0	11	14	19	0,17
HK CSTS 017 C 00	17	46	22,5	35	58,0	11	14	21	0,18
HK CSTS 020 C 00	20	53	27,5	38	64,5	13	15	30	0,25
HK CSTS 025 C 00	25	64	33,5	45	77,0	17	20	48	0,45
HK CSTS 030 C 00	30	73	40,0	51	87,5	19	22	62	0,67
HK CSTS 035 C 00	35	82	47,0	61	102,0	21	25	80	0,98
HK CSTS 040 C 00	40	92	52,0	69	115,0	23	28	100	1,35
HK CSTS 045 C 00	45	102	58,0	77	128,0	27	32	127	1,93
HK CSTS 050 C 00	50	112	62,0	88	144,0	30	35	156	2,65
HK CSTS 060 C 00	60	135	70,0	100	167,5	38	44	245	4,60
HK CSTS 070 C 00	70	160	80,0	115	195,0	42	49	315	7,00
HK CSTS 080 C 00	80	180	95,0	141	231,0	47	55	400	11,00