

Karakteristike

Priključak	Priključci za ulje: A + B = G 3/4"; Ulje curenja = G 1/4"
Izvedba	Standardna varijanta Type "C" with standard seal Four hole flange bolt circle 160 Vratilo Ø 40mm, duljina 79mm
Ulazni i povratni tlak s vodom za curenje ulja max.	210 bar

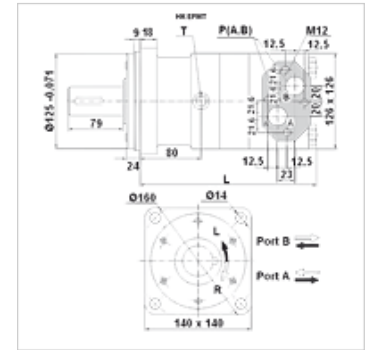

Napomena

Preporučuje se opće priključivanje voda za curenje ulja!

Artikli

Naziv	Protok max. (L/min)	Volumen trošenja (cc)	Broj okretaja min. (rpm)	Broj okretaja max. (rpm)	Okretni moment max. (N-m)	Pad tlaka max. (bar)	Pmax. at 0-100 rpm (bar)	Pmax. at 100-300 rpm (bar)	Pmax. at 300 rpm (bar)	L (mm)	Težina (kg)
HK EPMT 160 C	100	161,1	10	625	470	200	75	40	20	190	20,0
HK EPMT 200 C	125	201,4	10	625	590	200	75	40	20	195	22,5
HK EPMT 250 C	125	251,8	10	500	730	200	75	40	20	201	21,5
HK EPMT 315 C	125	326,3	10	380	950	200	75	40	20	211	22,0
HK EPMT 400 C	125	410,9	10	305	1080	180	75	40	20	221	23,0
HK EPMT 500 C	125	523,6	10	240	1220	160	75	40	-	235	24,0

max. pressure on shaft seal (without leak oil line) or pressure in leak oil line – Vrijednosti za okretni moment i padove tlaka vrijede za trajni pogon – pmax = maks. tlak

Pribor

HK V0 590 Šok ventil

Rezervni dijelovi

HK EP DS Brtveni set za hidraulični planetarni motor