

### Karakteristike

<b>Izvedba</b>	Cilindar klipa without mounting elements
<b>Radni tlak</b>	maks. 200 bar (u skladu s DIN EN 982)
<b>Ispitni tlak</b>	maks. 240 bar (u skladu s DIN EN 982)
<b>Temperaturno područje</b>	Standardna izvedba -15 °C do +80 °C
<b>Mediji</b>	HLP tekućina
<b>Materijal</b>	Klipnjača: čelik 20MnV6, krom 25 Micron +/- 5 Klipnjača: 120 sati otpornosti u NSS testu prema ISO 3768 Vodilica klipnjače: čelik 9SMn28 Priključni nastavak za ulje: čelik 9SMn28 Polirana cilindrična cijev: ČELIK 52.3 DIN 2393-ISO H9 Dno cilindra: FE 510-A105 Matica: čelik 8JUNI EN20898/2 Brtva TPM: NBR Klip: čelik 9SMn28 Brtva OR: NBR fluorosil viton Brtva TSE-TTS-TTI/L: NBR + tkanina / poliuretan Brtva GHM-GHK: NBR / poliuretan

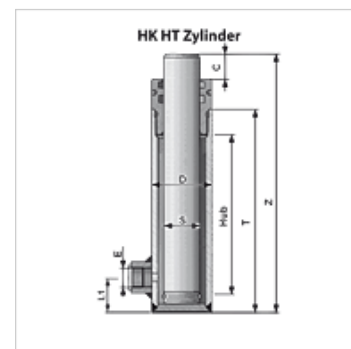

### Napomena

Brzina klipa u odnosu na standardne brtve: maks. 25m/min - 0,42m/sec.

Brzina klina u krajnjim položajima: maks. 6m/min - 0,10m/sec.

For these standard cylinders, it is recommended not to weld any fastenings to the cylinder liner (e.g. cardan mountings) as this could distort it.

### Opis

Our hydraulic cylinders and their components are designed for standard applications in industry and agriculture. They can be used only in some circumstances for applications in construction machinery. If this is your intention, please contact our technical personnel. The cylinders conform to the technical specifications in the catalogue or are designed to customers' specifications (approval drawing).

Molimo da pri odabiru, obradi i korištenju cilindara obratite pozornost na zadane smjernice

dEN ISO 4413 - Sigurnosno-tehničkih zahtjevi tehničkih postrojenja na fluide

i njihove komponente - kao i odredbe i sigurnosne zahtjeve

zakonskih propisa.

### Artikli

Naziv	Ø D (mm)	Ø S (mm)	Hod (mm)	Z (mm)	C (mm)	T (mm)	E	L1 (mm)	Težina (kg)
HK HT 02 30 0200	50	30	200	326	40,0	256,0	G 3/8"	23	3,64
HK HT 02 30 0250	50	30	250	376	40,0	303,0	G 3/8"	23	4,19
HK HT 02 30 0300	50	30	300	426	40,0	353,0	G 3/8"	23	4,75
HK HT 02 30 0350	50	30	350	476	40,0	403,0	G 3/8"	23	5,31
HK HT 02 30 0400	50	30	400	526	40,0	453,0	G 3/8"	23	5,86
HK HT 02 30 0500	50	30	500	626	40,0	553,0	G 3/8"	23	6,96
HK HT 03 40 0200	60	40	200	338	45,0	258,0	G 3/8"	26	5,64
HK HT 03 40 0300	60	40	300	438	45,0	358,0	G 3/8"	26	7,29
HK HT 03 40 0400	60	40	400	538	45,0	458,0	G 3/8"	26	8,98
HK HT 03 40 0500	60	40	500	638	45,0	558,0	G 3/8"	26	13,00
HK HT 03 40 0600	60	40	600	738	45,0	658,0	G 3/8"	26	12,28
HK HT 04 50 0300	70	50	300	450	50,0	365,0	G 3/8"	30	10,47
HK HT 04 50 0400	70	50	400	550	50,0	465,0	G 3/8"	30	12,86
HK HT 04 50 0500	70	50	500	650	50,0	565,0	G 3/8"	30	15,14
HK HT 04 50 0600	70	50	600	750	50,0	665,0	G 3/8"	30	17,50

Ø S = promjer klipnjače