

# KF-DI

Prsten za centriranje, Alu/FKM (FPM)

**HANSA FLEX**

## Karakteristike

<b>Primjena</b>	Brtvene komponente za male pribudne spojeve
<b>Izvedba</b>	Prsten za centriranje od aluminija s O prstenom od FKM (FPM)
<b>Norma</b>	DIN 28403 ISO 2861
<b>Materijal</b>	Prsten za centriranje od aluminija O-Ring: FKM (FPM)
<b>Temperaturno područje</b>	Aluminij od -156 °C do 150 °C FKM (FPM) von -20 °C bis 200 °C

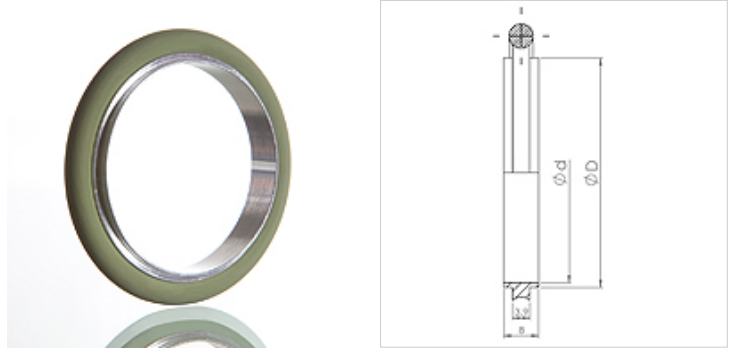

## Napomena

Područje tlaka od 10–7 mbar do 2,5 bar

## Napomene uz narudžbu

Ostale izvedbe na zahtjev

## Artikli

Naziv	DN	D (mm)	d (mm)
KF-DI 010	10	12,0	10,0
KF-DI 016	16	17,0	16,0
KF-DI 020	20	22,0	20,0
KF-DI 025	25	26,0	25,0
KF-DI 032	32	34,0	32,0
KF-DI 040	40	41,0	40,0
KF-DI 050	50	52,0	50,0