

## Karakteristike

Izvedba	Strugač
Brzina klizanja max.	1,0 m/s
Temperatura min.	-40 °C
Temperatura max.	120 °C
Mediji	Mineralna ulja Voda-zrak
Montaža	preša se u tvoreni utor
Materijal	(1) Metalna usna za struganje: mjed (INOX na zahtjev) (2) Usna za struganje od elastomera: NBR (FPM na zahtjev) (3) Čahura: čelik (INOX na zahtjev) (4) Odstojni elementi: čelik (INOX na zahtjev)
Primjena	Hidraulika

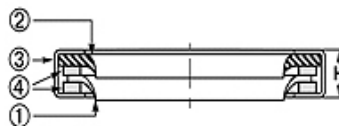

Toleranz / Tolerance		
d	D	L
f8 / h9	H8	+0,20 0

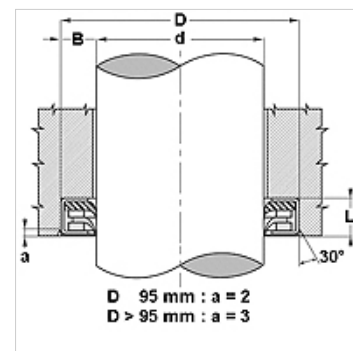

## Opis

potrebno malo mjesta  
učinkovito struganje u ekstremnim uvjetima.  
prikladno za led, blato i čestice koje se posebno prijanjaju  
plivajuća metalna usna za struganje omogućuje pomak klipnjača.

## Artikli

Naziv	d (mm)	D (mm)	L (mm)	H (mm)
DR 14	14	27	7,0	6,5
DR 16	16	29	7,0	6,5
DR 20	20	33	7,0	6,5
DR 22	22	35	7,0	6,5
DR 25	25	38	7,0	6,5
DR 28	28	41	7,0	6,5
DR 28 SS-FKM-SS	28	41	7,0	6,5
DR 30	30	43	7,5	7,0
DR 35	35	48	7,5	7,0
DR 36	36	49	7,5	7,0
DR 38	38	51	7,5	7,0
DR 40	40	53	7,5	7,0
DR 45	45	58	7,5	7,0
DR 50	50	64	8,0	7,5
DR 50-R-9975-R	50	64	8,0	7,5
DR 55	55	69	8,0	7,5
DR 60	60	74	8,0	7,5
DR 70	70	84	8,0	7,5
DR 75	75	89	8,0	7,5
DR 80	80	96	8,5	8,0
DR80 - SS-FKM-SS	80	96	8,5	8,0
DR 90	90	106	8,5	8,0
DR 150	150	170	9,0	8,5