

Karakteristike

Brzina klizanja max.	1,0 m/s
Tlačna čvrstoća prema DIN 53454 (N/mm ²)	270 N/mm ²
Površinsko pritiskanje	35 N/mm ²
Temperatura min.	-40 °C
Temperatura max.	120 °C
Mediji	Mineralna ulja
Montaža	umetnuti u utor
Materijal	pamučna tkanina s fenol smolom

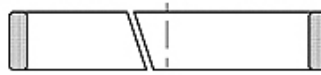

Toleranz / Tolerance		
D	d	L
H9	f8	+0,20 0

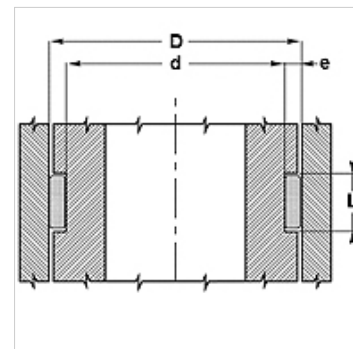

Napomena

Izračun poprečne sile; $F = p \times D \times L \times n$

F= maksimalna poprečna sila (N)

p= Maksimalno površinsko prešanje (N/mm²)

D x L= projicirana površina (mm²)

n= broj prstena

Opis

jednostavna obrada i montaža ugradnog utora

mali koeficijent trenja.

visoka nosivost

Artikli

Naziv	D (mm)	d (mm)	L (mm)
EGTP 250 970 600 A	60	55	9,7
EGTP 250 970 700 A	70	65	9,7
EGTP 251 500 550 A	55	50	15,0
EGTP 251 500 750 A	75	70	15,0
EGTP 251 500 850 A	85	80	15,0
EGTP 251 500 900 A	90	85	15,0
EGTP 251 500 950 A	95	90	15,0
EGTP 251 501 200 A	120	115	15,0
EGTP 302 500 900 A	90	85	15,0
EGTP 302 501 000 A	100	94	25,0
EGTP 303 001 200 A	120	114	30,0
EGTP 303 001 500 A	150	144	30,0
EGTP 353 001 300 A	130	123	30,0
EGTP 353 501 400 A	140	133	35,0
EGTP 353 501 500 A	150	143	35,0
EGTP 501 501 000 A	100	90	15,0
EGTP 501 501 100 A	110	100	15,0
EGTP 501 501 200 A	120	110	15,0
EGTP 501 501 300 A	130	120	15,0
EGTP 501 501 500 A	150	140	15,0
EGTP 501 621 000 A	100	90	16,2
EGTP 501 621 100 A	110	100	16,2
EGTP 501 621 200 A	120	110	16,2
EGTP 501 621 300 A	130	120	16,2
EGTP 501 621 400 A	140	130	16,2
EGTP 501 621 500 A	150	140	16,2
EGTP 502 321 600 A	160	150	23,2
EGTP 502 321 800 A	180	170	23,2