

Karakteristike

Izvedba	Strugač
Brzina klizanja max.	0,5 m/s
Temperatura min.	-20 °C
Temperatura max.	200 °C
Mediji	Mineralna ulja Emulzije vode
Montaža	preša se u utvoreni utor
Materijal	(1) Čahura: čelik Strugač: FPM
Primjena	Hidraulika

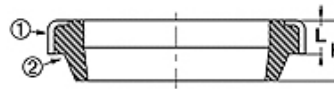

Toleranz / Tolerance		
d	D	L
h11	H8	+0,20 0

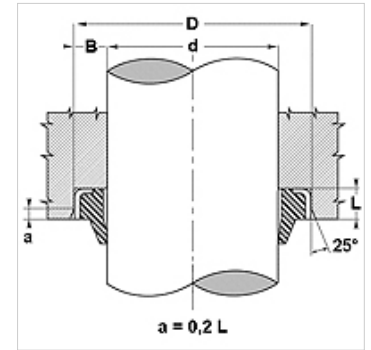

Opis

potrebno malo mjesta
Nema prodiranja prljavštine preko vanjskog metalnog prstena.
jednostavno rješenje.

Napomene uz narudžbu

Obratite nam se kod posebnim pogonskih uvjeta (tekućina, temperatura, tlak ...).

Artikli

Naziv	d (mm)	D (mm)	L (mm)	H (mm)
GA 16 22-3 FPM	16	22	3,0	4
GA 25 35-7 FPM	25	35	7,0	10
GA 30 40-7 FPM	30	40	7,0	10
GA 32 45-4 FPM	32	45	4,0	8
GA 45 55-7 FPM	45	55	7,0	10
GA 45 60-7 FPM	45	60	7,0	10
GA 50 56-5 FPM	50	56	5,0	8
GA 60 70-7 FPM	60	70	7,0	10
GA 63 75-7 FPM	63	75	7,0	10
GA 70 80-7 FPM	70	80	7,0	10