

Karakteristike

Izvedba	Brtva za struganje šipki
Radni tlak	do 10 bara
Brzina klizanja max.	1,0 m/s
Temperatura min.	-30 °C
Temperatura max.	90 °C
Mediji	Mineralna ulja Voda-zrak
Montaža	u otvorenim utorima B
Materijal	75° Shore A NBR
Primjena	Pneumatika

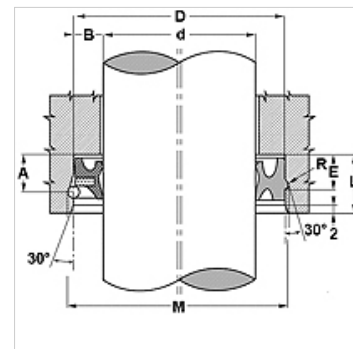

Toleranz / Tolerance				
d	D	M	A	E
H8 / f8	H10	± 0,10	+0,20 0	+0,25 0



Opis

brtva koja se ne haba.

Kombinirani element brtva-strugač

Artikli

Naziv	d (mm)	D (mm)	h (mm)	H (mm)	M (mm)	A (mm)	R (mm)
NPSL 16 26-7	16	26	7,0	9,5	28,00	8,50	1,10
NPSL 18 26-6	18	26	6,0	8,5	28,00	7,50	1,10
NPSL 20 30-7	20	30	7,0	9,5	32,00	8,80	1,40
NPSL 22 32-7	22	32	7,0	9,5	34,50	8,80	1,40
NPSL 25 35-7	25	35	7,0	9,5	37,50	8,80	1,40
NPSL 30 40-7	30	40	7,0	9,5	42,50	8,80	1,40
NPSL 32 42-7	32	42	7,0	9,5	44,50	8,80	1,40
NPSL 40 50-7	40	50	7,0	9,5	52,50	8,80	1,40