

### Karakteristike

Izvedba	Kompletni klip
Radni tlak	do 40 bara
Brzina klizanja max.	0,5 m/s
Temperatura min.	-30 °C
Temperatura max.	110 °C
Mediji	Mineralna ulja Voda-zrak
Montaža	s gumenom stranom gurnuti na nastavak klipnjače i pričvrstiti vijkom i maticom.
Materijal	85° Shore A NBR, s čeličnom jezgrom
Primjena	Hidraulika

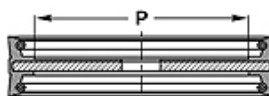

Toleranz / Tolerance		
D	d	E
H11	f8	± 0,50

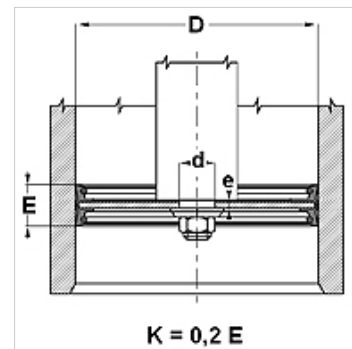

### Opis

Kompletni klip.

### Napomene uz narudžbu

Obratite nam se kod posebnim pogonskih uvjeta (tekućina, temperatura, tlak ...).  
Moguć je i drugi materijal: FPM.

### Artikli

Naziv	D (mm)	d (mm)	P (mm)	E (mm)	e (mm)
TDO 26	26	8,2	15,0	22	3,0
TDO 30	30	8,2	16,0	22	3,0
TDO 35	35	8,2	20,0	26	3,0
TDO 40	40	10,2	20,0	22	3,0
TDO 45	45	10,2	22,0	25	4,0
TDO 50	50	10,2	27,0	25	4,0
TDO 55	55	10,2	32,0	25	4,0
TDO 60	60	12,2	37,0	26	4,0
TDO 63	63	12,2	40,0	25	4,0
TDO 70	70	12,2	44,0	30	5,0
TDO 80	80	12,2	54,0	30	5,0
TDO 100	100	12,2	72,0	35	6,0
TDO 110	110	12,2	78,0	40	6,0
TDO 115	115	20,2	83,0	30	8,0
TDO 125	125	20,2	85,0	40	8,0
TDO 140	140	20,2	100,0	40	10,0
TDO 150	150	20,2	105,0	40	10,0
TDO 200	200	20,2	146,0	40	10,0
TDO 250	250	30,2	200,0	40	12,0
TDO 300	300	35,2	250,0	40	12,0