

Karakteristike

Izvedba	Kompletni klip
Radni tlak	do 10 bara
Brzina klizanja max.	1,0 m/s
Temperatura min.	-30 °C
Temperatura max.	110 °C
Mediji	Mineralna ulja Voda-zrak
Montaža	s gumenom stranom gurnuti na nastavak klipnjače i pričvrstiti vijkom i maticom.
Materijal	85° Shore A NBR, s čeličnom jezgrom
Primjena	Pneumatika

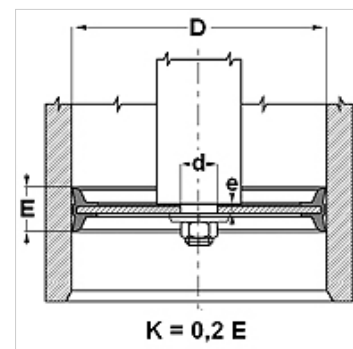

Toleranz / Tolerance		
D	d	E
H11	f8	± 0,50



Napomena

Tolerancija: D= H11; d= f8; E= +/-0,5

Opis

Kompletni klip.

Napomene uz narudžbu

Obratite nam se kod posebnim pogonskih uvjeta (tekućina, temperatura, tlak ...).

Moguć je i drugi materijal: FPM, EPDM.

Artikli

Naziv	D (mm)	d (mm)	P (mm)	E (mm)	e (mm)
TDOP 25	25	8	15,6	12	3,8
TDOP 32	32	8	20,0	15	3,8
TDOP 40	40	10	27,0	18	4,8
TDOP 50	50	10	37,0	18	4,8
TDOP 60	60	12	43,0	22	6,0
TDOP 63	63	12	43,0	22	6,0
TDOP 063-1	63	16	43,0	22	6,0
TDOP 65	65	12	43,0	25	6,0
TDOP 70	70	12	50,0	25	6,0
TDOP 80	80	16	55,0	24	6,0
TDOP 100	100	20	75,0	26	7,0
TDOP 125	125	20	95,0	26	9,6
TDOP 160	160	27	129,0	30	10,8
TDOP 200	200	27	169,0	35	11,4