

**Karakteristike**

Izvedba	Strugač
Brzina klizanja max.	0,5 m/s
Temperatura min.	-40 °C
Temperatura max.	130 °C
Mediji	Mineralna ulja Emulzije vode
Montaža	Strugač oblikovati u obliku bubrega i utisnuti u prihvatni utor
Materijal	90° Shore A NBR
Primjena	Hidraulika

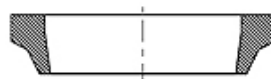

Toleranz / Tolerance			
d	D	L	C
h11	+0,20 0	+0,10 0	+0,20 0

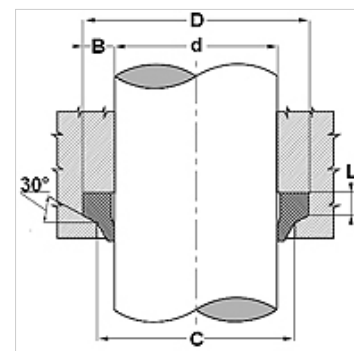

**Opis**

jednostavno rješenje.  
jednostavna montaža

**Napomene uz narudžbu**

Obratite nam se kod posebnim pogonskih uvjeta (tekućina, temperatura, tlak ...).  
Moguć je i drugi materijal: FPM.

**Artikli**

Naziv	d (mm)	D (mm)	L (mm)	C (mm)
WRS 751 25	19,05	31,75	5,3	25,45
WRS 100 150	25,40	38,10	5,3	31,80
WRS 129 179	33,00	45,70	5,3	39,40
WRS 157 207	40,00	52,70	5,3	46,40
WRS 187 237	47,62	60,32	5,3	54,02
WRS 196 246	50,00	62,70	5,3	56,40
WRS 200 250	50,80	63,50	5,3	57,20
WRS 220 270	56,00	68,70	5,3	62,40
WRS 225 275	57,15	69,85	5,3	63,55
WRS 236 286	60,00	72,70	5,3	66,40
WRS 248 298	63,00	75,70	5,3	69,40
WRS 275 325	70,00	82,70	5,3	76,40
WRS 300 350	76,20	88,90	5,3	82,40
WRS 315 365	80,00	92,70	5,3	86,40
WRS 325 375	82,55	95,25	5,3	88,95
WRS 346 396	88,00	100,70	5,3	94,40
WRS 374 424	95,00	107,70	5,3	101,40
WRS 600 650	152,40	165,10	5,3	158,40