

## Karakteristike

|                      |   |
|----------------------|---|
| Izvedba              | Strugač   |
| Brzina klizanja max. | 4,0 m/s   |
| Temperatura min.     | -40 °C  |
| Temperatura max.     | 110 °C  |
| Mediji               | mineralno ulje  |
| Montaža              | Strugač oblikovati u obliku bubrega i utisnuti u prihvatni utor     |
| Primjena             | For the usage at higher pollution, for e.g.:<br>Mining<br>foundries |
| Materijal            | PU 93° Shore A  |

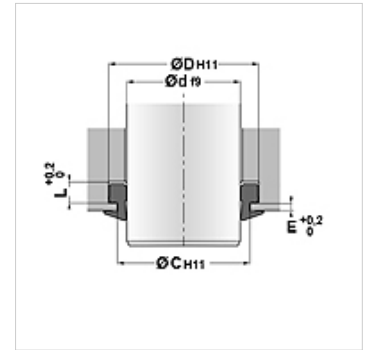
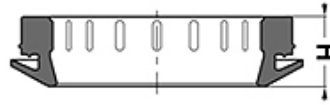

## Artikli

| Naziv  | C<br>(mm) | D<br>(mm) | d<br>(mm) | E<br>(mm) | H<br>(mm) | L<br>(mm) |
|--------|-----------|-----------|-----------|-----------|-----------|-----------|
| WAH-35 | 42,0      | 45,0      | 35        | 1,5       | 10,0      | 6,3       |
| WAH-36 | 41,5      | 44,0      | 36        | 1,5       | 8,0       | 5,0       |
| WAH-40 | 45,5      | 48,0      | 40        | 1,5       | 8,0       | 5,0       |
| WAH-45 | 50,5      | 53,0      | 45        | 1,5       | 8,0       | 5,0       |
| WAH-50 | 55,5      | 58,0      | 50        | 1,5       | 8,0       | 5,0       |
| WAH-56 | 63,0      | 66,0      | 56        | 1,5       | 10,0      | 6,3       |
| WAH-60 | 67,0      | 70,0      | 60        | 1,5       | 10,0      | 6,3       |
| WAH-63 | 70,0      | 73,0      | 63        | 1,5       | 10,0      | 6,3       |
| WAH-70 | 78,4      | 82,6      | 70        | 2,0       | 12,0      | 8,0       |
| WAH-80 | 87,0      | 90,0      | 80        | 1,5       | 10,0      | 6,3       |
| WAH-90 | 96,0      | 102,2     | 90        | 2,8       | 12,4      | 7,1       |