

Tulajdonságok

| | |
|-----------------------------|--|
| Csatlakozás 1 | hengeres BSP belső menet |
| 1 tömítési forma | A idom |
| Csatlakozás 2 | metrikus hengeres külső menet |
| 2 tömítési forma | 24°-os belső kúp |
| Szerkezeti mód | Felcsavarozható csavarzat |
| Szerkezeti forma | egyenes |
| Szabvány | DIN 2353 ISO 8434-1 |
| Szállítás terjedelme | Csonk hollandi anyával és vágógyűrűvel |
| Anyag | Nemesacél |

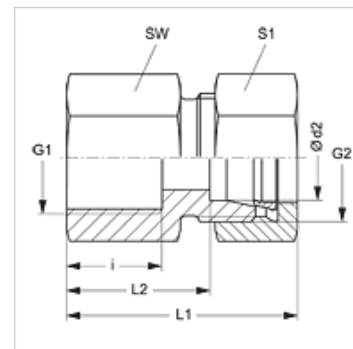

Cikk

| Megnevezés | Kivitel | Üzemi nyomás bar | Ø d2 (mm) | G1 | G2 | i (mm) | L1 (mm) | L2 (mm) | SW (mm) | S1 |
|---------------------|---------|------------------|-----------|--------------|------------|--------|---------|---------|---------|----|
| GAR NW 04 HL VA | L | PN 315 | 6 | G 1/8" -28 | M 12 x 1,5 | 12,0 | 34,0 | 19,0 | 14 | 14 |
| GAR NW 04 HL 1/4 VA | L | PN 315 | 6 | G 1/4" -19 | M 12 x 1,5 | 12,0 | 34,0 | 19,0 | 14 | 14 |
| GAR NW 04 HL 3/8 VA | L | PN 315 | 6 | G 3/8" -19 | M 12 x 1,5 | 12,0 | 36,0 | 21,0 | 22 | 14 |
| GAR NW 04 HL 1/2 VA | L | PN 315 | 6 | G 1/2" -14 | M 12 x 1,5 | 20,0 | 46,0 | 31,0 | 27 | 14 |
| GAR NW 06 HL VA | L | PN 315 | 8 | G 1/4" -19 | M 14 x 1,5 | 17,0 | 39,0 | 24,0 | 19 | 17 |
| GAR NW 06 HL 3/8 VA | L | PN 315 | 8 | G 3/8" -19 | M 14 x 1,5 | 17,0 | 36,0 | 21,0 | 22 | 17 |
| GAR NW 06 HL 1/2 VA | L | PN 315 | 8 | G 1/2" -14 | M 14 x 1,5 | 20,0 | 44,0 | 29,0 | 27 | 17 |
| GAR NW 08 HL VA | L | PN 315 | 10 | G 1/4" -19 | M 16 x 1,5 | 17,0 | 40,0 | 25,0 | 19 | 19 |
| GAR NW 08 HL 3/8 VA | L | PN 315 | 10 | G 3/8" -19 | M 16 x 1,5 | 17,0 | 40,0 | 26,0 | 22 | 19 |
| GAR NW 08 HL 1/2 VA | L | PN 315 | 10 | G 1/2" -14 | M 16 x 1,5 | 20,0 | 45,0 | 30,0 | 27 | 19 |
| GAR NW 10 HL 1/4 VA | L | PN 315 | 12 | G 1/4" -19 | M 18 x 1,5 | 17,0 | 41,0 | 25,0 | 19 | 22 |
| GAR NW 10 HL VA | L | PN 315 | 12 | G 3/8" -19 | M 18 x 1,5 | 17,0 | 41,0 | 26,0 | 22 | 22 |
| GAR NW 10 HL 1/2 VA | L | PN 315 | 12 | G 1/2" -14 | M 18 x 1,5 | 20,0 | 44,0 | 30,0 | 27 | 22 |
| GAR NW 13 HL 3/8 VA | L | PN 315 | 15 | G 3/8" -19 | M 22 x 1,5 | 17,0 | 46,0 | 27,0 | 24 | 27 |
| GAR NW 13 HL VA | L | PN 315 | 15 | G 1/2" -14 | M 22 x 1,5 | 20,0 | 45,0 | 30,0 | 27 | 27 |
| GAR NW 16 HL 3/8 VA | L | PN 315 | 18 | G 3/8" -19 | M 26 x 1,5 | 17,5 | 47,0 | 26,5 | 27 | 32 |
| GAR NW 16 HL VA | L | PN 315 | 18 | G 1/2" -14 | M 26 x 1,5 | 20,0 | 46,0 | 29,5 | 27 | 32 |
| GAR NW 20 HL 1/2 VA | L | PN 160 | 22 | G 1/2" -14 | M 30 x 2 | 20,0 | 55,0 | 33,5 | 32 | 36 |
| GAR NW 20 HL VA | L | PN 160 | 22 | G 3/4" -14 | M 30 x 2 | 22,0 | 51,0 | 34,5 | 32 | 36 |
| GAR NW 25 HL VA | L | PN 160 | 28 | G 1" -11 | M 36 x 2 | 24,5 | 53,5 | 37,0 | 41 | 41 |
| GAR NW 32 HL VA | L | PN 160 | 35 | G 1.1/4" -11 | M 45 x 2 | 26,5 | 60,5 | 39,0 | 50 | 50 |
| GAR NW 40 HL VA | L | PN 160 | 42 | G 1.1/2" -11 | M 52 x 2 | 28,5 | 63,5 | 40,5 | 55 | 60 |
| | | | | | | | | | | |
| GAR NW 03 HS 1/8 VA | S | PN 400 | 6 | G 1/8" -28 | M 14 x 1,5 | 12,0 | 34,0 | 19,0 | 14 | 14 |
| GAR NW 03 HS VA | S | PN 400 | 6 | G 1/4" -19 | M 14 x 1,5 | 17,0 | 41,0 | 26,0 | 19 | 17 |
| GAR NW 04 HS VA | S | PN 400 | 8 | G 1/4" -19 | M 16 x 1,5 | 17,0 | 41,0 | 26,0 | 19 | 19 |
| GAR NW 06 HS VA | S | PN 400 | 10 | G 3/8" -19 | M 18 x 1,5 | 17,0 | 42,0 | 26,5 | 24 | 22 |
| GAR NW 06 HS 1/2 VA | S | PN 400 | 10 | G 1/2" -14 | M 18 x 1,5 | 20,0 | 49,5 | 30,5 | 27 | 22 |
| GAR NW 08 HS 1/4 VA | S | PN 400 | 12 | G 1/4" -19 | M 20 x 1,5 | 17,0 | 46,0 | 27,5 | 22 | 24 |
| GAR NW 08 HS VA | S | PN 400 | 12 | G 3/8" -19 | M 20 x 1,5 | 17,0 | 42,0 | 26,5 | 24 | 24 |
| GAR NW 08 HS 1/2 VA | S | PN 400 | 12 | G 1/2" -14 | M 20 x 1,5 | 20,0 | 50,0 | 30,5 | 27 | 24 |
| GAR NW 10 HS VA | S | PN 400 | 14 | G 1/2" -14 | M 22 x 1,5 | 20,0 | 50,0 | 32,0 | 27 | 27 |
| GAR NW 13 HS VA | S | PN 400 | 16 | G 1/2" -14 | M 24 x 1,5 | 20,0 | 50,0 | 31,5 | 27 | 30 |
| GAR NW 16 HS 3/8 VA | S | PN 315 | 20 | G 3/8" -19 | M 30 x 2 | 17,0 | 50,0 | 30,0 | 24 | 36 |
| GAR NW 16 HS 1/2 VA | S | PN 315 | 20 | G 1/2" -14 | M 30 x 2 | 20,0 | 57,0 | 32,5 | 32 | 36 |
| GAR NW 16 HS VA | S | PN 315 | 20 | G 3/4" -14 | M 30 x 2 | 22,0 | 56,0 | 34,5 | 36 | 36 |
| GAR NW 20 HS VA | S | PN 315 | 25 | G 1" -11 | M 36 x 2 | 24,5 | 61,5 | 37,5 | 41 | 46 |
| GAR NW 25 HS VA | S | PN 315 | 30 | G 1.1/4" -11 | M 42 x 2 | 26,5 | 68,5 | 42,0 | 50 | 50 |
| GAR NW 32 HS VA | S | PN 250 | 38 | G 1.1/2" -11 | M 52 x 2 | 28,5 | 74,5 | 43,5 | 60 | 60 |

Kivitel: LL = igen könnyű L = könnyű S = nehéz - PN = névleges nyomás PB = max. üzemi nyomás - Ø d2 = cső külső átmérője

Termékváltozatok

| | |
|----------------|--------------------------------------|
| GAR | Felcsavarozható-csavarzat, Acél |
| GAR MG | Felcsavarozható csavarzat, Sárgaréz |
| XGAR VA | Felcsavarozható-csavarzat, Nemesacél |