

Tulajdonságok

Csatlakozás 1	hengeres BSP belső menet
Csatlakozás 2	hengeres BSP belső menet
Szerkezeti mód	Összekötő csonk
Szerkezeti forma	egyenes
Anyag	Nemesacél

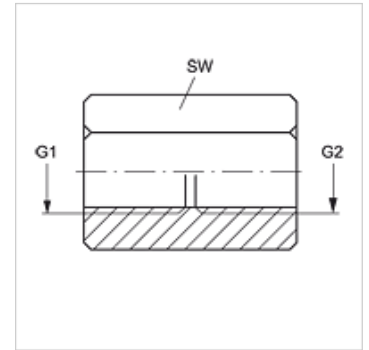
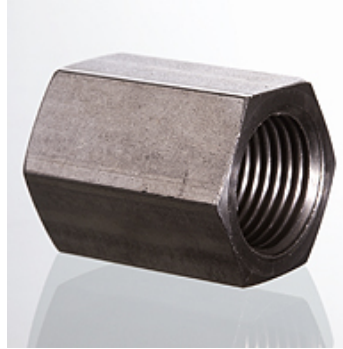

Cikk

Megnevezés	G1	G2	SW (mm)
G 02 IR VA	G 1/8" -28	G 1/8" -28	14
G 04 IR 02 VA	G 1/4" -19	G 1/8" -28	17
G 04 IR VA	G 1/4" -19	G 1/4" -19	17
G 06 IR 04 VA	G 3/8" -19	G 1/4" -19	22
G 06 IR VA	G 3/8" -19	G 3/8" -19	22
G 08 IR 04 VA	G 1/2" -14	G 1/4" -19	27
G 08 IR 06 VA	G 1/2" -14	G 3/8" -19	27
G 08 IR VA	G 1/2" -14	G 1/2" -14	27
G 12 IR 06 VA	G 3/4" -14	G 3/8" -19	32
G 12 IR VA	G 3/4" -14	G 3/4" -14	32
G 16 IR 08 VA	G 1" -11	G 1/2" -14	41
G 16 IR 12 VA	G 1" -11	G 3/4" -14	41
G 16 IR VA	G 1" -11	G 1" -11	41
G 20 IR 16 VA	G 1.1/4" -11	G 1" -11	50
G 20 IR VA	G 1.1/4" -11	G 1.1/4" -11	50
G 24 IR 20 VA	G 1.1/2" -11	G 1.1/4" -11	55
G 24 IR VA	G 1.1/2" -11	G 1.1/2" -11	55
G 32 IR 24 VA	G 2" -11	G 1.1/2" -11	70
G 32 IR VA	G 2" -11	G 2" -11	70

SW = kulcsméret

Termékváltozatok

G IR Összekötő-csonk, Acél