

Caratteristiche

Tipo	Curva da 90°
Norma	DIN 2391/C
Materiale	Acciaio ST 37.4 NBK (1.0255)
Protezione superficiale	fosfatato ed oliato

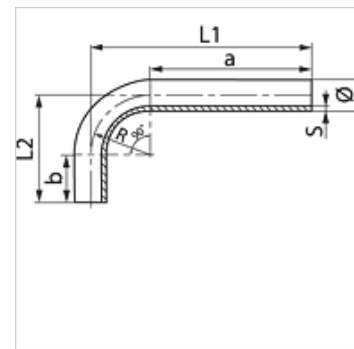

Descrizione

Curve a saldatura continua da 90° per perdite di carico minime.

Articolo

Denominazione	diametro esterno del tubo Ø (mm)	Ø interno (mm)	S (mm)	Raggio di curvatura R (mm)	a (mm)	b (mm)	L1 (mm)	L2 (mm)
RB 14-1.5	14,0	11,0	1,50	30	200,0	40,0	230,0	70,0
RB 15-1.5	15,0	12,0	1,50	30	200,0	40,0	230,0	70,0
RB 15-2	15,0	11,0	2,00	30	200,0	40,0	230,0	70,0
RB 16-2	16,0	12,0	2,00	30	200,0	40,0	230,0	70,0
RB 18-1.5	18,0	15,0	1,50	36	200,0	35,0	236,0	71,0
RB 18-2	18,0	14,0	2,00	36	200,0	35,0	236,0	72,0
RB 20-2	20,0	16,0	2,00	36	200,0	45,0	236,0	81,0
RB 20-2.5	20,0	15,0	2,50	36	200,0	45,0	236,0	81,0
RB 20-3	20,0	14,0	3,00	36	200,0	45,0	236,0	81,0
RB 22-1.5	22,0	19,0	1,50	38	200,0	40,0	238,0	78,0
RB 22-2	22,0	18,0	2,00	38	200,0	40,0	238,0	78,0
RB 22-2.5	22,0	17,0	2,50	38	200,0	40,0	238,0	78,0
RB 22-3.5	22,0	15,0	3,50	38	200,0	40,0	238,0	78,0
RB 25-2	25,0	21,0	2,00	44	200,0	50,0	244,0	94,0
RB 25-2.5	25,0	20,0	2,50	44	200,0	50,0	244,0	94,0
RB 25-3	25,0	19,0	3,00	44	200,0	50,0	244,0	94,0
RB 25-4	25,0	17,0	4,00	44	200,0	50,0	244,0	94,0
RB 28-1.5	28,0	25,0	1,50	48	200,0	50,0	248,0	98,0
RB 28-2	28,0	24,0	2,00	48	200,0	50,0	248,0	98,0
RB 28-3	28,0	22,0	3,00	48	200,0	50,0	248,0	98,0
RB 30-2.5	30,0	25,0	2,50	50	200,0	60,0	250,0	110,0
RB 30-3	30,0	24,0	3,00	50	200,0	60,0	250,0	110,0
RB 30-4	30,0	22,0	4,00	50	200,0	60,0	250,0	110,0
RB 35-2	35,0	31,0	2,00	60	200,0	65,0	260,0	125,0
RB 35-3	35,0	29,0	3,00	60	200,0	65,0	260,0	125,0
RB 38-2.5	38,0	33,0	2,50	65	200,0	75,0	265,0	140,0
RB 38-3	38,0	32,0	3,00	65	200,0	75,0	265,0	140,0
RB 38-4	38,0	30,0	4,00	65	200,0	75,0	265,0	140,0
RB 38-5	38,0	28,0	5,00	65	200,0	75,0	265,0	140,0
RB 42-2	42,0	38,0	2,00	80	200,0	85,0	280,0	165,0
RB 42-3	42,0	36,0	3,00	80	200,0	85,0	280,0	165,0
RB 50-6	50,0	38,0	6,00	210	100,0	100,0	310,0	310,0
RB 65-8	65,0	49,0	8,00	210	110,0	110,0	320,0	320,0
RB 80-10	80,0	60,0	10,00	150	120,0	120,0	330,0	330,0