

# FEDERRING

Rosetta elastica

**HANSA FLEX**

## Caratteristiche

<b>Tipo</b>	Rosetta elastica
<b>Norma</b>	DIN 127 Forma B
<b>Materiale</b>	Acciaio per molle

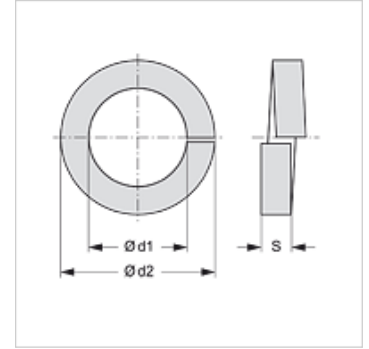

## Articolo

Denominazione	Ø d1 (mm)	Ø d2 (mm)	S (mm)
<b>FEDERRING M8</b>	8,1	14,8	2,0
<b>FEDERRING M10</b>	10,2	18,1	2,2
<b>FEDERRING M12</b>	12,2	21,1	2,5
<b>FEDERRING M14</b>	14,2	24,1	3,0
<b>FEDERRING M16</b>	16,2	27,4	3,5
<b>FEDERRING M20</b>	20,2	33,6	4,0