

# PN HN

Niplo a pressione, AGN

**HANSA FLEX**

## Caratteristiche

<b>Campo di impiego</b>	Niplo a pressione per flessibili di tipo da HD 100 a HD 400, flessibili KP e TE
<b>Attacco 1</b>	Filetto esterno NPT
<b>Tenuta 1</b>	con guarnizione filetto, cono interno da 60° supplementare
<b>Abbreviazione</b>	AGN
<b>Materiale</b>	Acciaio
<b>Protezione superficiale</b>	con rivestimento elettrolitico

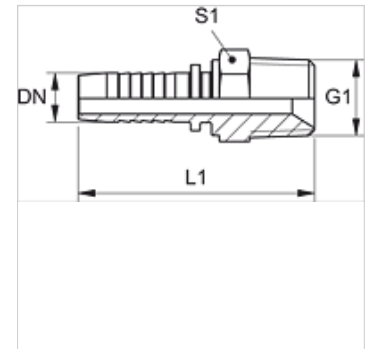

## Nota

Scegliere il giunto femmina adatto in base al tipo di tubo flessibile.

## Articolo

Denominazione	DN	Size	pollice	Pressione d'esercizio (bar)	G1	L1 (mm)	S1
PN 04 HN	5	3	3/16"	350,0	1/8" -27 NPT	44,0	12
PN 04 HN 06	5	3	3/16"	350,0	1/4" -18 NPT	47,5	14
PN 06 HN 02	6	4	1/4"	350,0	1/8" -27 NPT	50,0	12
PN 06 HN	6	4	1/4"	350,0	1/4" -18 NPT	53,5	14
PN 06 HN 10	6	4	1/4"	275,0	3/8" -18 NPT	54,0	19
PN 08 HN 06	8	5	5/16"	350,0	1/4" -18 NPT	53,5	14
PN 08 HN 10	8	5	5/16"	275,0	3/8" -18 NPT	54,0	19
PN 10 HN 06	10	6	3/8"	275,0	1/4" -18 NPT	55,0	16
PN 10 HN	10	6	3/8"	275,0	3/8" -18 NPT	56,5	19
PN 10 HN 13	10	6	3/8"	240,0	1/2" -14 NPT	61,0	22
PN 13 HN 10	12	8	1/2"	240,0	3/8" -18 NPT	57,5	19
PN 13 HN	12	8	1/2"	240,0	1/2" -14 NPT	62,0	22
PN 13 HN 20	12	8	1/2"	210,0	3/4" -14 NPT	64,5	27
PN 16 HN 13	16	10	5/8"	210,0	1/2" -14 NPT	68,0	24
PN 16 HN 20	16	10	5/8"	210,0	3/4" -14 NPT	68,0	27
PN 20 HN 13	19	12	3/4"	210,0	1/2" -14 NPT	74,5	27
PN 20 HN	19	12	3/4"	210,0	3/4" -14 NPT	76,5	27
PN 20 HN 25	19	12	3/4"	170,0	1" -11,5 NPT	80,5	36
PN 25 HN 20	25	16	1"	170,0	3/4" -14 NPT	84,5	36
PN 25 HN	25	16	1"	170,0	1" -11,5 NPT	88,5	36
PN 25 HN 32	25	16	1"	150,0	1.1/4" -11,5 NPT	91,5	46
PN 32 HN	31	20	1.1/4"	150,0	1.1/4" -11,5 NPT	101,0	46
PN 40 HN	38	24	1.1/2"	140,0	1.1/2" -11,5 NPT	105,5	50
PN 50 HN	51	32	2"	140,0	2" -11,5 NPT	127,5	65

## Varianti dei prodotti

PN HN VA Niplo a pressione, AGN, Acciaio inossidabile