

PN SF 45

Nipplo a pressione, SFL W45°

HANSA FLEX

Caratteristiche

| | |
|--------------------------------|--|
| Campo di impiego | Nipplo a pressione per flessibili di tipo da HD 100 a HD 400, flessibili KP e TE |
| Attacco 1 | Attacco flangiato SAE 3000 PSI |
| Tenuta 1 | con guarnizione piana con SF O-ring |
| Abbreviazione | SFL |
| Norma | SAE J518 ISO 6162-1 |
| Materiale | Acciaio |
| Protezione superficiale | con rivestimento elettrolitico |

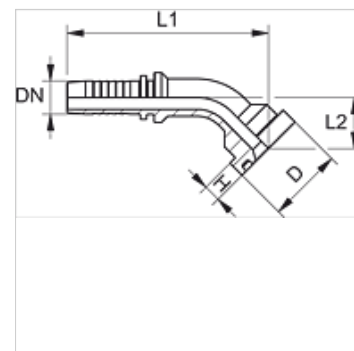

Nota

Scegliere il giunto femmina adatto in base al tipo di tubo flessibile.

Articolo

| Denominazione | DN | Size | pollice | Grandezza flangia | Pressione d'esercizio (bar) | D (mm) | H (mm) | L1 (mm) | L2 (mm) |
|------------------|----|------|---------|-------------------|-----------------------------|--------|--------|---------|---------|
| PN 13 SF 45 | 12 | 8 | 1/2" | 1/2" | 350,0 | 30,2 | 6,80 | 81,0 | 21,0 |
| PN 13 SF 20 45 | 12 | 8 | 1/2" | 3/4" | 350,0 | 38,1 | 6,80 | 84,5 | 24,5 |
| PN 16 SF 13 45 | 16 | 10 | 5/8" | 1/2" | 350,0 | 30,2 | 6,80 | 100,0 | 26,5 |
| PN 16 SF 20 45 | 16 | 10 | 5/8" | 3/4" | 350,0 | 38,1 | 6,80 | 96,5 | 27,5 |
| PN 20 SF 45 | 19 | 12 | 3/4" | 3/4" | 350,0 | 38,1 | 6,80 | 107,5 | 28,0 |
| PN 20 SF 25 45 | 19 | 12 | 3/4" | 1" | 320,0 | 44,4 | 8,10 | 109,5 | 30,0 |
| PN 25 SF 20 45 | 25 | 16 | 1" | 3/4" | 320,0 | 38,1 | 6,70 | 128,0 | 30,0 |
| PN 25 SF 45 | 25 | 16 | 1" | 1" | 320,0 | 44,4 | 8,00 | 132,0 | 30,5 |
| PN 25 SF 32 45 | 25 | 16 | 1" | 1.1/4" | 280,0 | 50,8 | 8,10 | 134,0 | 32,0 |
| PN 32 SF 25 45 | 31 | 20 | 1.1/4" | 1" | 280,0 | 44,4 | 8,10 | 156,0 | 41,0 |
| PN 32 SF 45 | 31 | 20 | 1.1/4" | 1.1/4" | 280,0 | 50,8 | 8,10 | 156,0 | 36,0 |
| PN 32 SF 40 45 | 31 | 20 | 1.1/4" | 1.1/2" | 210,0 | 60,3 | 8,10 | 160,0 | 40,0 |
| PN 40 SF 45 | 38 | 24 | 1.1/2" | 1.1/2" | 210,0 | 60,3 | 8,10 | 184,0 | 46,0 |
| PN 40 SF 50 45 | 38 | 24 | 1.1/2" | 2" | 210,0 | 71,4 | 9,60 | 184,0 | 46,0 |
| PN 50 SF 40 45 | 51 | 32 | 2" | 1.1/2" | 210,0 | 60,3 | 8,10 | 182,0 | 42,0 |
| PN 50 SF 45 | 51 | 32 | 2" | 2" | 210,0 | 71,4 | 9,60 | 219,0 | 50,0 |
| PN 50 SF 60 45 | 51 | 32 | 2" | 2.1/2" | 175,0 | 84,0 | 9,60 | 212,0 | 57,0 |
| PN 60 SF 45 | 60 | 40 | 2.3/8" | 2.1/2" | 175,0 | 84,0 | 9,60 | 237,0 | 50,0 |
| PN 60 SF 45 L 60 | 60 | 40 | 2.3/8" | 2.1/2" | 175,0 | 84,0 | 9,60 | 237,0 | 60,0 |
| PN 76 SF 60 45 | 76 | 48 | 3" | 2.1/2" | 160,0 | 84,0 | 9,53 | 230,0 | 56,3 |
| PN 76 SF 45 | 76 | 48 | 3" | 3" | 160,0 | 101,6 | 9,53 | 228,0 | 55,0 |

Varianti dei prodotti

PN SF 45 VA Nipplo a pressione, SFL W45°, Acciaio inossidabile