

K 407-1-1

Bussola di rinforzo

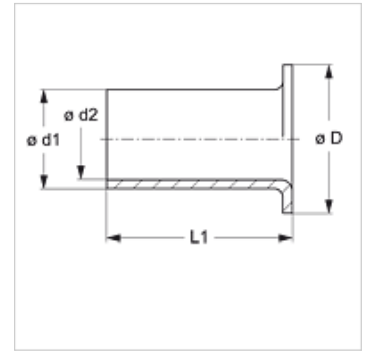

Articolo

Denominazione	D (mm)	$\varnothing d1$ (mm)	$\varnothing d2$ (mm)	L1 (mm)
K 407-1-1	3,8	3	1,7	8