

HK DLMDL

Rotaie di smorzamento DLMDL

HANSA FLEX

Caratteristiche

Materiale NBR

Utilizzo per motori elettrici forma IM B35

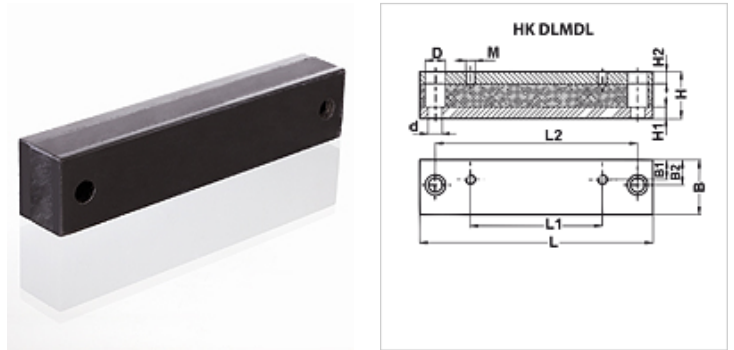

Descrizione

per l'abbassamento del livello sonoro e l'attenuazione delle vibrazioni
gomma naturale isolante con binari in acciaio vulcanizzata
nessun collegamento metallico tra sovrastruttura e basamento

Articolo

Denominazione	Dimensione Motore IEC	B	B1	B2	D	d	H	H1	H2	L	L1	L2	M	Peso
		(mm)	(mm)	(mm)	(mm)	(mm)	(mm)	(mm)	(mm)	(mm)	(mm)	(mm)		(kg)
HK DLMDL 90L	90L	50,00	22,0	25,0	20,0	14,00	40,0	8,00	12	240,0	125,0	205,0	M8	2,10
HK DLMDL 100L	100L	50,00	24,0	25,0	20,0	14,00	40,0	8,00	12	240,0	140,0	205,0	M10	2,25
HK DLMDL 112M	112M	50,00	20,0	25,0	20,0	14,00	40,0	8,00	12	240,0	140,0	205,0	M10	2,30
HK DLMDL 132S	132S	50,00	20,0	25,0	20,0	14,00	45,0	8,00	12	285,0	140,0	245,0	M10	2,42
HK DLMDL 132M	132M	50,00	20,0	25,0	20,0	14,00	45,0	8,00	12	285,0	178,0	245,0	M10	2,42
HK DLMDL 160M	160M	70,00	28,0	35,0	26,0	18,00	60,0	15,00	15	340,0	210,0	300,0	M12	7,50
HK DLMDL 160L	160L	70,00	28,0	35,0	26,0	18,00	60,0	15,00	15	416,0	254,0	370,0	M12	7,50
HK DLMDL 180M	180M	70,00	35,0	35,0	26,0	18,00	60,0	15,00	15	416,0	241,0	370,0	M12	8,00
HK DLMDL 180L	180L	70,00	35,0	35,0	26,0	18,00	60,0	15,00	15	446,0	279,0	400,0	M12	8,00
HK DLMDL 200L	200L	70,00	35,0	35,0	32,0	22,00	60,0	15,00	15	496,0	305,0	430,0	M16	8,55