

Caratteristiche

Tipo	Anello scanalato per lo stelo
Pressione d'esercizio	fino a 400 bar
Velocità di scorrimento max.	0,5 m/s
Temperatura min.	-30 °C
Temperatura max.	80 °C
Mezzi	Oli minerali
Montaggio	nelle scanalature aperte B nelle scanalature chiuse negli spazi di montaggio aperti
Materiale	PUR
Applicazione	Idraulica

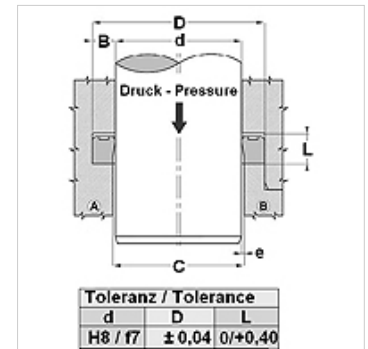

Druck bar	Spaltmaß / Clearance			
	e (mm)			
	TS-TS...L		TS...-AI-TS...-LA	
	d<60mm	d>60mm	d<60mm	d>60mm
50	<0,40	<0,50	<0,60	<0,80
100	<0,30	<0,40	<0,60	<0,80
200	<0,20	<0,30	<0,40	<0,60
300	<0,15	<0,20	<0,30	<0,40
400	<0,10	<0,15	<0,20	<0,30
500			<0,10	<0,15



Toleranz / Tolerance		
d	D	L
H8 / f7	± 0,04	0/+0,40

Descrizione

Considerevole resistenza all'abrasione.
Ottima tenuta per basse pressioni.
Rapido cambio del carico.

Avvertenza per l'ordinazione

Si possono realizzare in tempi brevi guarnizioni di tenuta con diametro da 20 a 510 mm.

Articolo

Denominazione	d (mm)	D (mm)	L (mm)
TS 12 18	12	18,0	5,0
TS 16 22	16	22,0	4,5
TS 16 24-1	16	24,0	7,0
TS 18 25	18	25,0	5,7
TS 20 25	20	25,0	3,5
TS 20 25-1	20	25,0	4,5
TS 20 26	20	26,0	6,0
TS 20 27	20	27,0	6,5
TS 20 30	20	30,0	8,0
TS 20 30-1	20	30,0	9,0
TS 20 30-2	20	30,0	11,0
TS 21 27	24	27,0	5,0
TS 22 28	22	28,0	5,0
TS 22 30	22	30,0	8,0
TS 22 32-1	22	32,0	9,0
TS 24 30	24	30,0	5,0
TS 25 32	25	32,0	5,0
TS 25 35	25	35,0	6,0
TS 25 35-2	25	35,0	10,0
TS 25 35-5	25	35,0	11,0
TS 25 36	25	36,0	6,0
TS 30 38	30	38,0	9,0
TS 30 40-1	30	40,0	8,0
TS 32 40	32	40,0	9,0
TS 32 42-1	32	42,0	9,0
TS 32 42-2	32	42,0	11,0
TS 35 43-1	35	43,0	9,0
TS 35 45	35	45,0	8,0
TS 36 44	36	44,0	9,0
TS 38 45	38	45,0	7,0
TS 40 50	40	50,0	7,0
TS 42 53	42	53,0	10,0
TS 45 53-1	45	53,0	7,0
TS 45 53	45	53,0	9,0
TS 46 54	46	54,0	9,0
TS 50 62	50	62,0	11,0
TS 56 66-1	56	66,0	7,5
TS 56 66	56	66,0	11,0



Articolo

Denominazione	d (mm)	D (mm)	L (mm)
TS 60 70-3	60	70,0	13,0
TS 61 69	61	69,0	9,0
TS 63 71	63	70,0	9,0
TS 66 80	66	80,0	11,0
TS 68 76	68	76,0	9,0
TS 70 80	70	80,0	8,0
TS 70 80-2	70	80,0	13,0
TS 72 78	72	78,0	7,0
TS 76 84	76	84,0	9,0
TS 85 97	85	97,0	9,5
TS 88 96	88	96,0	9,0
TS 90 96	90	96,0	5,5
TS 90 100	90	100,0	7,5
TS 91 99	91	99,0	9,0
TS 107 115	107	115,0	9,0
TS 126 134	126	134,0	9,0
TS 145 153	145	153,0	9,0
TS 147 155	147	155,0	11,0
TS 175 183	175	183,5	9,0
TS 221 229	221	229,5	13,0