

AC OR AOL

O-Ring , DKOL climatizzazione

Caratteristiche

Temperatura min. -40 °C

Temperatura max. 125 °C

Materiale NBR

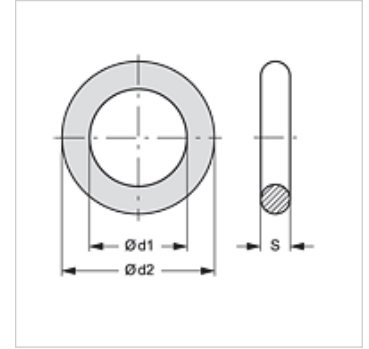

Articolo

Denominazione	per flessibili DN	$\varnothing d1$ (mm)	$\varnothing d2$ (mm)	S (mm)
AC OR AOL 20	19	20	24	2,0
AC OR AOL 25	25	26	30	2,0
AC OR AOL 32	31	32	37	2,5