

AC OR

O-ring per nipplo AC-Clip

Caratteristiche

Tipo Anello di tenuta per nipplo AC-Clip

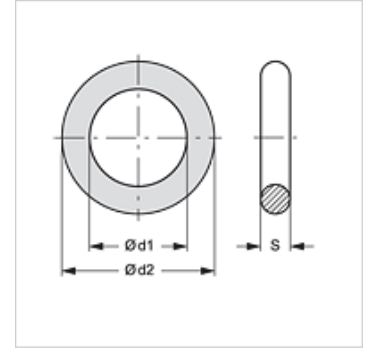

Articolo

Denominazione	per flessibili DN	$\varnothing d1$ (mm)	$\varnothing d2$ (mm)	S (mm)
AC OR 05	05	3,5	5,5	1,0
AC OR 08	08	5,5	7,5	1,0
AC OR 10	10	8,0	10,0	1,0
AC OR 13	12	9,5	12,5	1,5
AC OR 16	16	12,0	16,0	2,0
AC OR 20	19	15,5	19,5	2,0