

# K-ELEKTRO-KABELAUFROLL POLY

Electrical cable reel (polypropylene) easy mounting on the wall or ceiling

**HANSA FLEX**

## Caratteristiche

Tipo di cavo	HO5VV-F
Intensità di corrente	Max. 10 A
Attacco	SchuKo plug
per tensione	230 V, 50 Hz
Potenza assorbita	Max. 1000 W (fully wound), max. 2000 W (fully unwound)
Angolo di rotazione	180°

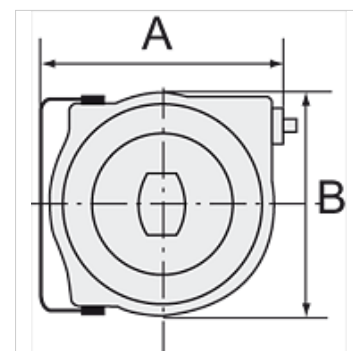

## Nota

Altri dati su richiesta.

## Descrizione

High-quality, polypropylene housing. Includes a thermal circuit breaker. In case of overloading, a thermal overload protective circuit cuts off the electrical power supply automatically.

## Articolo

Denominazione	A (mm)	B (mm)	Lunghezza (m)
K- 07 10 03 48	335,0	290,0	15