

K-WV 5/2 MECHA ROLLENHEBEL M5

5/2-way valve, mechanically operated, with roller lever

HANSA FLEX

Caratteristiche

Pressione d'esercizio	0 - 10 bar
Campo della temperatura:	-20 °C to +70 °C
Misurazione del valore della portata	At P1 = 8 bar, P2 = 6 bar and pressure drop $\Delta p = 1$ bar
Corpo valvola	Aluminium alloy

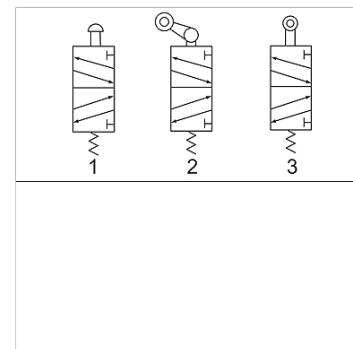

Nota

Altri dati su richiesta.

Articolo

Denominazione	Attacco	Attacco per sfiato	Portata (L/min)	Numero schema
K- 07 15 03 12	G 1/8	G 1/8	450	3
K- 07 15 03 13	G 1/4	G 1/8	550	3