

# K-SCHL-AUFROLLER LU WA S

Hose reels for compressed air and water, heavy-duty type

**HANSA FLEX**

## Caratteristiche

Materiale del tubo flessibile	Polyurethane
Pressione d'esercizio	max. 10 bar
Temperatura d'esercizio	-10 °C to +40 °C
Elemento di fissaggio	Wall, floor or ceiling
Ingresso	Hose stem 8 mm

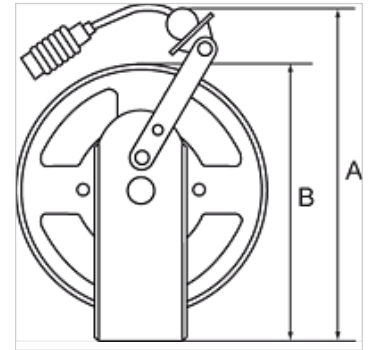

## Nota

Altri dati su richiesta.

## Descrizione

Heavy-duty steel design for industrial applications. Blue, powder-coated housing. An automatic latching mechanism allows the hose to be engaged at any length. Enclosed spring. Precise locking device for continuous feeding or latching mechanism. Reel guide prevents excessive wear on the hose.

## Articolo

Denominazione	Dimensione tubo flessibile	A (mm)	B (mm)	Lunghezza tubo flessibile (m)
K- 07 10 06 24	10 mm x 6,5 mm	420,0	353,0	10
K- 07 10 06 25	10 mm x 6,5 mm	420,0	353,0	20
K- 07 10 06 26	12 mm x 8 mm	420,0	353,0	15
K- 07 10 06 27	16 mm x 11 mm	420,0	353,0	15