

K-KONSOLE STAHL VS INFI

Console made of steel galvanized

HANSA FLEX

Caratteristiche

Materiale Galvanised steel

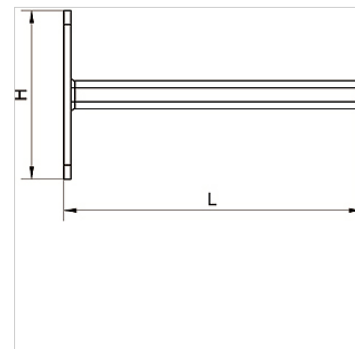

Articolo

Denominazione	H (mm)	L (mm)	Lunghezza (m)
K- 07 40 54 90	120,0	280,0	0,280