

Savybės

Panaudojimas Aušinimo ir tepimo linijos metalams apdoroti pjaunant.

Konstrukcija Laikančioji plieninė spiralė su vidine PVC žarna es. įsukamas kakliukas as. plieninė tūta nikeluotas paviršius

Savybės Visiškai sandari ranka galima sulenkti į beveik bet kurią padėtį tvirta atspari alyvai, tepalui ir t. t.

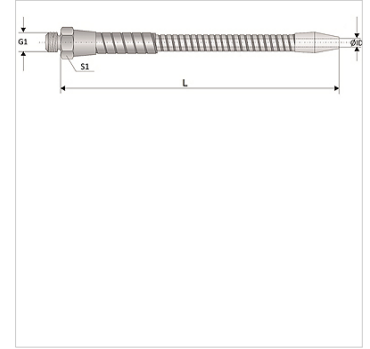

užsakymo nuorodos

Kiti matmenys pagal užklausimą

Prekė

Pavadinimas	G1	ID (mm)	S1 (mm)	Nominalusis ilgis (+/-5 mm)
NIAG 1/8-200	R 1/8"	8,0	15,0	200
NIAG 1/8-250	R 1/8"	8,0	15,0	250
NIAG 1/8-320	R 1/8"	8,0	15,0	320
NIAG 1/8-400	R 1/8"	8,0	15,0	400
NIAG 1/8-500	R 1/8"	8,0	15,0	500
NIAG 1/8-630	R 1/8"	8,0	15,0	630
NIAG 1/8-800	R 1/8"	8,0	15,0	800
NIAG 1/4-200	R 1/4"	10,0	19,0	200
NIAG 1/4-250	R 1/4"	10,0	19,0	250
NIAG 1/4-320	R 1/4"	10,0	19,0	320
NIAG 1/4-400	R 1/4"	10,0	19,0	400
NIAG 1/4-500	R 1/4"	10,0	19,0	500
NIAG 1/4-630	R 1/4"	10,0	19,0	630
NIAG 1/4-800	R 1/4"	10,0	19,0	800
NIAG 3/8-250	R 3/8"	10,0	24,0	250
NIAG 3/8-300	R 3/8"	10,0	24,0	300
NIAG 3/8-320	R 3/8"	10,0	24,0	320
NIAG 3/8-400	R 3/8"	10,0	24,0	400
NIAG 3/8-500	R 3/8"	10,0	24,0	500
NIAG 3/8-630	R 3/8"	10,0	24,0	630
NIAG 3/8-800	R 3/8"	10,0	24,0	800
NIAG 1/2-250	R 1/2"	12,0	27,0	250
NIAG 1/2-320	R 1/2"	12,0	27,0	320
NIAG 1/2-400	R 1/2"	12,0	27,0	400
NIAG 1/2-500	R 1/2"	12,0	27,0	500
NIAG 1/2-630	R 1/2"	12,0	27,0	630
NIAG 1/2-800	R 1/2"	12,0	27,0	800