

Savybės

Medžiaga NBR

Naudojimas Elektriniams varikliams, konstrukcija IM B35

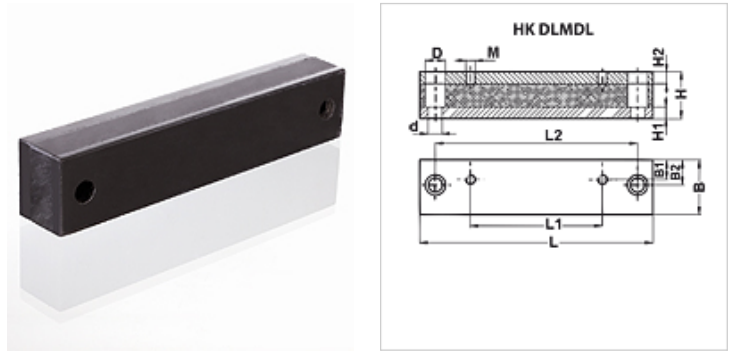

Aprašas

garso lygio mažinimui ir vibracijos slopinimui
slopinanti natūrali guma su plieno bėgeliais, vulkanizuota
antžeminės ir požeminės konstrukcijos neįjungia jokie metaliniai elementai

Prekė

Pavadinimas	IEC variklio konstrukcinis dydis	B	B1	B2	D	d	H	H1	H2	L	L1	L2	M	Svoris
		(mm)	(mm)	(mm)	(mm)	(mm)	(mm)	(mm)	(mm)	(mm)	(mm)	(mm)		(kg)
HK DLMDL 90L	90L	50,00	22,0	25,0	20,0	14,00	40,0	8,00	12	240,0	125,0	205,0	M8	2,10
HK DLMDL 100L	100L	50,00	24,0	25,0	20,0	14,00	40,0	8,00	12	240,0	140,0	205,0	M10	2,25
HK DLMDL 112M	112M	50,00	20,0	25,0	20,0	14,00	40,0	8,00	12	240,0	140,0	205,0	M10	2,30
HK DLMDL 132S	132S	50,00	20,0	25,0	20,0	14,00	45,0	8,00	12	285,0	140,0	245,0	M10	2,42
HK DLMDL 132M	132M	50,00	20,0	25,0	20,0	14,00	45,0	8,00	12	285,0	178,0	245,0	M10	2,42
HK DLMDL 160M	160M	70,00	28,0	35,0	26,0	18,00	60,0	15,00	15	340,0	210,0	300,0	M12	7,50
HK DLMDL 160L	160L	70,00	28,0	35,0	26,0	18,00	60,0	15,00	15	416,0	254,0	370,0	M12	7,50
HK DLMDL 180M	180M	70,00	35,0	35,0	26,0	18,00	60,0	15,00	15	416,0	241,0	370,0	M12	8,00
HK DLMDL 180L	180L	70,00	35,0	35,0	26,0	18,00	60,0	15,00	15	446,0	279,0	400,0	M12	8,00
HK DLMDL 200L	200L	70,00	35,0	35,0	32,0	22,00	60,0	15,00	15	496,0	305,0	430,0	M16	8,55