

Īpašības

Savienojums 1	BSP ārējā vītne, cilindriska
Blīvējuma veids 1	Gredzens ar noblīvētu malu
Savienojums 2 + 3	metriskā ārējās vītnes, cilindriskās
Blīvējuma veids 2 + 3	24° iekšējais konuss
Modelis	Atvāzams veidgabals bez droseles
Konstrukcija	T-veida
Standarts	DIN 3865
Piegādes apjoms	lemava ar uznavuzgriezni un griešanas gredzenu
Materiāls	Tērauds
Virsmas aizsardzība	galvaniskais pārklājums

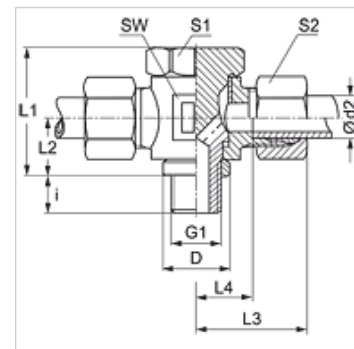

Norāde

Norādes par montāžu, uzstādīšanu, spiediena noslodzi un pieļaujamo ekspluatācijas temperatūru norādītas cauruļu veidgabalu tehniskajā informācijā.

Izstrādājums

Apzīmējums	Sērija	Ekspluatācijas spiediens bar	Ø d2 (mm)	G1	D (mm)	i (mm)	L1 (mm)	L2 (mm)	L3 (mm)	L4 (mm)	SW (mm)	S1	S2
STR NW 04 HL	L	PN 250	6	G 1/8" -28	14,0	8	24	10,5	27	12,0	17	17	14
STR NW 06 HL	L	PN 250	8	G 1/4" -19	18,0	12	30	14,0	29	14,5	22	19	17
STR NW 08 HL	L	PN 250	10	G 1/4" -19	18,0	12	30	14,0	30	15,5	22	19	19
STR NW 10 HL	L	PN 250	12	G 3/8" -19	22,0	12	36	16,5	33	18,0	27	24	22
STR NW 13 HL	L	PN 250	15	G 1/2" -14	26,0	14	45	21,5	37	21,5	32	30	27
STR NW 16 HL	L	PN 250	18	G 1/2" -14	26,5	14	45	21,5	37	21,0	32	30	32
STR NW 20 HL	L	PN 160	22	G 3/4" -14	32,0	16	53	24,0	44	27,5	41	36	36
STR NW 25 HL	L	PN 160	28	G 1" -11	39,0	18	66	30,5	49	32,0	50	46	41
STR NW 32 HL	L	PN 160	35	G 1.1/4" -11	49,0	20	76	35,5	58	36,0	60	55	50
STR NW 40 HL	L	PN 160	42	G 1.1/2" -11	55,0	22	87	40,5	63	40,5	70	60	60
STR NW 03 HS	S	PN 315	6	G 1/4" -19	18,0	12	30	14,0	31	16,5	22	19	17
STR NW 04 HS	S	PN 315	8	G 1/4" -19	18,0	12	30	14,0	31	16,5	22	19	19
STR NW 06 HS	S	PN 315	10	G 3/8" -19	22,0	12	36	16,5	35	18,5	27	24	22
STR NW 08 HS	S	PN 315	12	G 3/8" -19	22,0	12	36	16,5	35	18,5	27	24	24
STR NW 10 HS	S	PN 315	14	G 1/2" -14	26,0	14	45	21,5	40	22,5	32	30	27
STR NW 13 HS	S	PN 315	16	G 1/2" -14	26,0	14	45	21,5	40	22,0	32	30	30
STR NW 16 HS	S	PN 160	20	G 3/4" -14	32,0	16	53	24,0	48	26,5	41	36	36
STR NW 20 HS	S	PN 160	25	G 1" -11	39,0	18	66	30,5	56	31,5	50	46	46
STR NW 25 HS	S	PN 160	30	G 1.1/4" -11	49,0	20	76	35,5	64	37,0	60	55	50
STR NW 32 HS	S	PN 160	38	G 1.1/2" -11	55,0	22	87	40,5	72	41,5	70	60	60

Sērija: LL = ļoti vieglā L = vieglā S = smagā – PN = nominālais spiediens PB = maks. ekspluatācijas spiediens – Ø d2 = cauruļes ārējais diametrs

Izstrādājumu varianti

XSTR Atvāzams veidgabals bez droseles, T-veida, lemava (bez uznavuzgriežņa un griešanas gredzena)