

Īpašības

Savienojums 1	BSP ārējā vītne, cilindriska
Bļivējuma veids 1	B veida
Savienojums 2	BSP iekšējā vītne, cilindriska
Modelis	Noņemams redukcijas savienojums
Konstrukcija	garš
Standarts	DIN 2353 ISO 8434-1
Materiāls	Tērauds
Virsmas aizsardzība	galvaniskais pārklājums

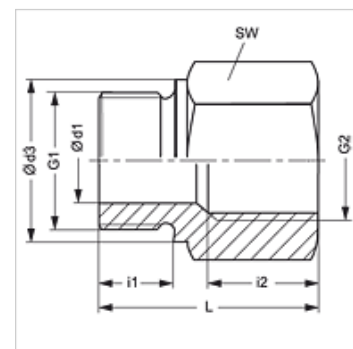

Norāde

Norādes par montāžu, uzstādīšanu, spiediena noslodzi un pieļaujamo ekspluatācijas temperatūru norādītas cauruļu veidgabalu tehniskajā informācijā.

Izstrādājums

Apzīmējums	Ekspluatācijas spiediens bar	Ø d1 (mm)	G1	G2	Ø d3 (mm)	i1 (mm)	i2 (mm)	L (mm)	SW (mm)
RIL NW 03 06	PN 400	4	G 1/8" -28	G 1/4" -19	14	8	17,0	31,0	19
RIL NW 03 10	PN 400	4	G 1/8" -28	G 3/8" -19	14	8	17,0	32,0	24
RIL NW 06 03	PN 400	5	G 1/4" -19	G 1/8" -28	18	12	12,0	28,0	19
RIL NW 06 06	PN 400	5	G 1/4" -19	G 1/4" -19	18	12	17,0	35,0	19
RIL NW 06 10	PN 400	5	G 1/4" -19	G 3/8" -19	18	12	17,0	36,0	24
RIL NW 06 13	PN 400	5	G 1/4" -19	G 1/2" -14	18	12	20,0	40,0	27
RIL NW 06 20	PN 315	5	G 1/4" -19	G 3/4" -14	18	12	22,0	43,0	36
RIL NW 10 06	PN 400	8	G 3/8" -19	G 1/4" -19	22	12	17,0	36,0	22
RIL NW 10 10	PN 400	8	G 3/8" -19	G 3/8" -19	22	12	17,0	35,5	24
RIL NW 10 13	PN 400	8	G 3/8" -19	G 1/2" -14	22	12	20,0	41,0	27
RIL NW 10 20	PN 315	8	G 3/8" -19	G 3/4" -14	22	12	22,0	44,0	36
RIL NW 13 10	PN 315	12	G 1/2" -14	G 3/8" -19	26	14	17,0	36,0	27
RIL NW 13 13	PN 315	12	G 1/2" -14	G 1/2" -14	26	14	20,0	42,0	27
RIL NW 13 20	PN 315	12	G 1/2" -14	G 3/4" -14	26	14	22,0	46,0	36
RIL NW 13 25	PN 315	12	G 1/2" -14	G 1" -11	26	14	24,5	49,0	41
RIL NW 13 32	PN 160	10	G 1/2" -14	G 1.1/4" -11	26	14	26,5	53,0	55
RIL NW 20 13	PN 315	16	G 3/4" -14	G 1/2" -14	32	16	20,0	41,0	32
RIL NW 20 20	PN 315	16	G 3/4" -14	G 3/4" -14	32	16	22,0	46,0	36
RIL NW 20 25	PN 315	16	G 3/4" -14	G 1" -11	32	16	24,5	51,0	41
RIL NW 20 32	PN 160	16	G 3/4" -14	G 1.1/4" -11	32	16	26,5	55,0	55
RIL NW 20 40	PN 160	16	G 3/4" -14	G 1.1/2" -11	32	16	28,5	57,0	60
RIL NW 25 20	PN 315	20	G 1" -11	G 3/4" -14	39	18	22,0	47,0	41
RIL NW 25 32	PN 160	20	G 1" -11	G 1.1/4" -11	39	18	26,5	57,0	55
RIL NW 25 40	PN 160	20	G 1" -11	G 1.1/2" -11	39	18	28,5	59,0	60
RIL NW 32 25	PN 160	25	G 1.1/4" -11	G 1" -11	49	20	24,5	52,0	50
RIL NW 32 40	PN 160	25	G 1.1/4" -11	G 1.1/2" -11	49	20	28,5	60,0	60
RIL NW 40 32	PN 160	32	G 1.1/2" -11	G 1.1/4" -11	55	22	26,5	58,0	55
RIL NW 50 40	PN 160	40	G 2" -11	G 1.1/2" -11	68	24	28,5	62,0	70

PN = nominālais spiediens PB = maks. ekspluatācijas spiediens

Izstrādājumu varianti

RIL MG	Noņemams redukcijas savienojums, garš, Misiņš
RIL VA	Noņemams redukcijas savienojums, garš, Centrējošais gredzens no alumīnija ar Viton gredzenblīvi