

AFS G (3000 PSI)

leskrūvējams SAE atloks, BSP

Īpašības

Spiediena sērija	3000 psi
Standarts	SAE J 518 C ISO 6162
Konstrukcija	Taisna
Modelis	leskrūvējams SAE atloks
Stiprinājums	Urbums skrūvei
Piegādes apjoms	tikai atloks
Materiāls	S355J2G3 (ST52.3)
Virsmas aizsardzība	ieeļļošana ar melno eļļu

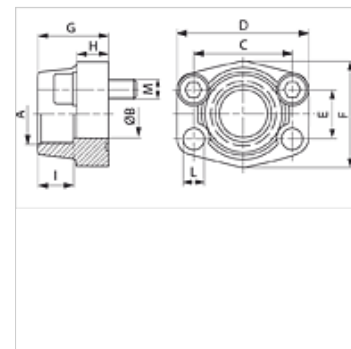
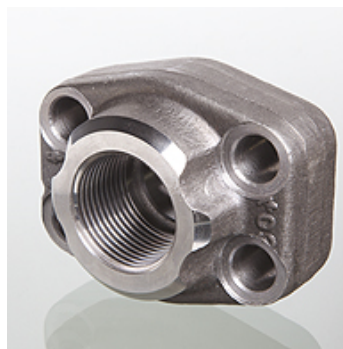

Norāde

Norādītais maksimālais ekspluatācijas spiediens attiecas uz atloku! Reālo ekspluatācijas spiedienu nosaka caurule (sieniņu biezums) un tās kvalitāte!

Ieteicamās skrūves ir norādītas ailēs M (metriskās) vai M (collu).

Izstrādājums

Apzīmējums	PB 10.9 (bar)	Tipizmērs	A	Ø B (mm)	C (mm)	D (mm)	E (mm)	F (mm)	G (mm)	H (mm)	L (mm)	M metr.	M collas
AFS 80 G 3/8	350	1/2"	G 3/8" -19	13	38,1	54	17,5	46	36	16	9,0	M 8 x 30	5/16" x 1.1/4"
AFS 80 G 1/2	350	1/2"	G 1/2" -14	13	38,1	54	17,5	46	36	16	9,0	M 8 x 30	5/16" x 1.1/4"
AFS 100 G 1/2	350	3/4"	G 1/2" -14	13	47,6	65	22,2	50	36	18	11,0	M 10 x 35	3/8" x 1.1/2"
AFS 100 G 3/4	350	3/4"	G 3/4" -14	19	47,6	65	22,2	50	36	18	11,0	M 10 x 35	3/8" x 1.1/2"
AFS 102 G 1/2	315	1"	G 1/2" -14	13	52,4	70	26,2	55	38	18	11,0	M 10 x 35	3/8" x 1.1/2"
AFS 102 G 3/4	315	1"	G 3/4" -14	19	52,4	70	26,2	55	35	21	11,0	M 10 x 35	3/8" x 1.1/2"
AFS 102 G 1	315	1"	G 1" -11	25	52,4	70	26,2	55	38	18	11,0	M 10 x 35	3/8" x 1.1/2"
AFS 104 G 3/4	250	1.1/4"	G 3/4" -14	19	58,7	79	30,2	68	41	21	11,5	M 10 x 40	7/16" x 1.1/2"
AFS 104 G 1 M10	250	1.1/4"	G 1" -11	25	58,7	81	30,2	65	42	25	11,5	M 10 x 40	-
AFS 104 G 1 M12	250	1.1/4"	G 1" -11	25	58,7	81	30,2	65	42	25	13,0	M 12 x 40	-
AFS 104 G1 1/4 M10	250	1.1/4"	G 1.1/4" -11	32	58,7	79	30,2	68	41	21	11,5	M 10 x 40	-
AFS 104 G1 1/4 M12	250	1.1/4"	G 1.1/4" -11	32	58,7	79	30,2	68	41	21	13,0	M 12 x 40	-
AFS 106 G 3/4	200	1.1/2"	G 3/4" -14	19	69,9	93	35,7	78	45	25	13,5	M 12 x 45	1/2" x 1.3/4"
AFS 106 G 1	200	1.1/2"	G 1" -11	25	69,9	93	35,7	78	45	25	13,5	M 12 x 45	1/2" x 1.3/4"
AFS 106 G 1 1/4	200	1.1/2"	G 1.1/4" -11	32	69,9	95	35,7	78	45	27	13,5	M 12 x 45	1/2" x 1.3/4"
AFS 106 G 1 1/2	200	1.1/2"	G 1.1/2" -11	38	69,9	93	35,7	78	45	25	13,5	M 12 x 45	1/2" x 1.3/4"
AFS 108 G 1	200	2"	G 1" -11	25	77,8	102	42,9	90	45	25	13,5	M 12 x 45	1/2" x 1.3/4"
AFS 108 G 1 1/4	200	2"	G 1.1/4" -11	32	77,8	102	42,9	90	45	25	13,5	M 12 x 45	1/2" x 1.3/4"
AFS 108 G 1 1/2	200	2"	G 1.1/2" -11	38	77,8	102	42,9	90	45	25	13,5	M 12 x 45	1/2" x 1.3/4"
AFS 108 G 2	200	2"	G 2" -11	51	77,8	102	42,9	90	45	25	13,5	M 12 x 45	1/2" x 1.3/4"
AFS 110 G 1 1/2	160	2.1/2"	G 1.1/2" -11	38	88,9	114	50,8	105	50	25	13,5	M 12 x 45	1/2" x 1.3/4"
AFS 110 G 2	160	2.1/2"	G 2" -11	51	88,9	114	50,8	105	50	25	13,5	M 12 x 45	1/2" x 1.3/4"
AFS 110 G 2 1/2	160	2.1/2"	G 2.1/2" -11	63	88,9	114	50,8	105	50	25	13,5	M 12 x 45	1/2" x 1.3/4"
AFS 112 G 2 1/2	138	3"	G 2.1/2" -11	63	106,4	134	61,9	124	50	27	17,5	M 16 x 50	5/8" x 2"
AFS 112 G 3	138	3"	G 3" -11	73	106,4	134	61,9	124	50	27	17,5	M 16 x 50	5/8" x 2"
AFS 114 G 3	35	3.1/2"	G 3" -11	73	120,7	152	69,9	136	48	27	17,5	M 16 x 50	5/8" x 2"
AFS 114 G 3 1/2	35	3.1/2"	G 3.1/2" -11	89	120,7	152	69,9	136	48	27	17,5	M 16 x 50	5/8" x 2"
AFS 116 G 3 1/2	35	4"	G 3.1/2" -11	89	130,2	162	77,8	146	48	27	17,5	M 16 x 50	5/8" x 2"
AFS 116 G 4	35	4"	G 4" -11	99	130,2	162	77,8	146	48	27	17,5	M 16 x 50	5/8" x 2"

PN = nominālais spiediens PB = maks. ekspluatācijas spiediens

Izstrādājumu varianti

AFS G M (3000 PSI) leskrūvējams SAE atloks, BSP, ar metrisku skrūvju komplektu un apaļa šķērsriezuma gredzenu

AFS G U (3000 PSI) leskrūvējams SAE atloks, BSP, ar UNC skrūvju komplektu un apaļa šķērsriezuma gredzenu