

# GFS STRE (3000 PSI)

Piemetināms SAE slēptais atloks

**HANSA FLEX**

## Īpašības

Spiediena sērija	3000 psi
Standarts	SAE J 518 C ISO 6162
Papildinājums modelim	ND 40
Konstrukcija	Taisna
Modelis	Piemetināms SAE slēptais atloks
Stiprinājums	Iekšējās vītnes metriskajām skrūvēm Skrūves
Materiāls	S355J2G3 (ST52.3)
Virsmas aizsardzība	Ieeļļošana ar melno eļļu

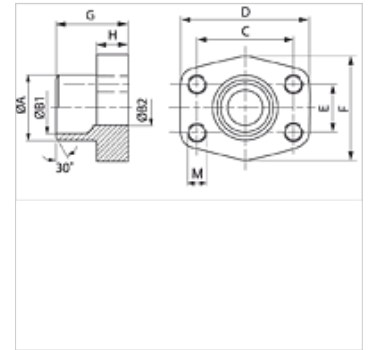

## Norāde

Norādītais maksimālais ekspluatācijas spiediens attiecas uz atloku! Reālo ekspluatācijas spiedienu nosaka caurule (sieniņu biezums) un tās kvalitāte!

## Izstrādājums

Apzīmējums	PB 10.9 (bar)	Tipizmērs	Caurule	A (mm)	B1 (mm)	B2 (mm)	G (mm)	C (mm)	D (mm)	E (mm)	F (mm)	H (mm)	M metr.
GFS 80 STRE 21.3	350	1/2"	21,3 x 2,6	22,0	16,0	13	35,0	38,1	54	17,5	46	16,0	M 8
GFS 100 STRE 26.9	350	3/4"	26,9 x 2,6	28,0	21,5	19	35,0	47,6	65	22,2	50	18,0	M 10
GFS 102 STRE 33.7	315	1"	33,7 x 3,2	35,0	27,0	25	38,0	52,4	70	26,2	55	18,0	M 10
GFS 104 STRE 42.4	250	1.1/4"	42,4 x 3,2	43,0	36,0	31	41,0	58,7	79	30,2	68	21,0	M 10
GFS 106 STRE 48.3	200	1.1/2"	48,3 x 3,2	49,0	42,0	38	44,0	69,9	93	35,7	78	25,0	M 12
GFS 108 STRE 48.3	200	2"	48,3 x 3,2	49,0	42,0	42	45,0	77,8	102	42,9	90	25,0	M 12
GFS 108 STRE 60.3	200	2"	60,3 x 3,6	61,0	53,0	49	45,0	77,8	102	42,9	90	25,0	M 12
GFS 110 STRE 60.3	160	2.1/2"	60,3 x 3,6	61,0	53,0	53	50,0	88,9	114	50,8	105	25,0	M 12
GFS 110 STRE 76.1	160	2.1/2"	76,1 x 3,6	77,0	70,0	62	50,0	88,9	114	50,8	105	25,0	M 12
GFS 112 STRE 88.9	138	3"	88,9 x 3,6	90,0	82,0	74	51,0	106,4	134	61,9	124	26,0	M 16
GFS 114 STRE 76.1	35	3.1/2"	76,1 x 3,6	77,0	70,0	70	48,0	120,7	152	69,9	136	26,0	M 16
GFS 114 STRE 88.9	35	3.1/2"	88,9 x 3,6	90,0	82,0	82	48,0	120,7	152	69,9	136	26,0	M 16
GFS 116 STRE 114	35	4"	114,3 x 3,6	115,0	107,0	102	48,0	130,2	162	77,8	146	26,0	M 16
GFS 116 STRE 88.9	35	4"	88,9 x 3,6	90,0	82,0	82	48,0	130,2	162	77,8	146	26,0	M 16
GFS 118 STRE 139	35	5"	139,7 x 4	140,2	131,0	120	50,0	152,4	184	92,1	180	28,0	M 16

PN = nominālais spiediens PB = maks. ekspluatācijas spiediens