

Īpašības

Savienojums 1	NPT ārējās vītnes
Bļivējuma veids 1	Vītnes bļivējums
Savienojums 2	UN/UNF ārējās vītnes
Bļivējuma veids 2	74° ārējais konuss
Modelis	leskrūvējama iemava
Konstrukcija	Taisna
Materiāls	Centrējošais gredzens no alumīnija ar Viton gredzenbļīvi

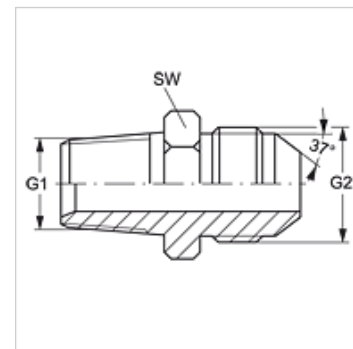

Izstrādājums

Apzīmējums	G1	G2	SW (mm)
GE HN 02 HJ 04 VA	1/8" -27 NPT	7/16" -20 UNF	13
GE HN 02 HJ 05 VA	1/8" -27 NPT	1/2" -20 UNF	14
GE HN 02 HJ 06 VA	1/8" -27 NPT	9/16" -18 UNF	16
GE HN 04 HJ VA	1/4" -18 NPT	7/16" -20 UNF	14
GE HN 04 HJ 05 VA	1/4" -18 NPT	1/2" -20 UNF	14
GE HN 04 HJ 06 VA	1/4" -18 NPT	9/16" -18 UNF	16
GE HN 04 HJ 08 VA	1/4" -18 NPT	3/4" -16 UNF	19
GE HN 06 HJ VA	3/8" -18 NPT	9/16" -18 UNF	19
GE HN 06 HJ 04 VA	3/8" -18 NPT	7/16" -20 UNF	19
GE HN 06 HJ 05 VA	3/8" -18 NPT	1/2" -20 UNF	19
GE HN 06 HJ 08 VA	3/8" -18 NPT	3/4" -16 UNF	19
GE HN 06 HJ 10 VA	3/8" -18 NPT	7/8" -14 UNF	24
GE HN 08 HJ 04 VA	1/2" -14 NPT	7/16" -20 UNF	22
GE HN 08 HJ 06 VA	1/2" -14 NPT	9/16" -18 UNF	22
GE HN 08 HJ VA	1/2" -14 NPT	3/4" -16 UNF	22
GE HN 08 HJ 10 VA	1/2" -14 NPT	7/8" -14 UNF	24
GE HN 08 HJ 12 VA	1/2" -14 NPT	1.1/16" -12 UN	27
GE HN 08 HJ 16 VA	1/2" -14 NPT	1.5/16" -12 UN	35
GE HN 12 HJ 08 VA	3/4" -14 NPT	3/4" -16 UNF	27
GE HN 12 HJ 10 VA	3/4" -14 NPT	7/8" -14 UNF	27
GE HN 12 HJ VA	3/4" -14 NPT	1.1/16" -12 UN	27
GE HN 12 HJ 16 VA	3/4" -14 NPT	1.5/16" -12 UN	36
GE HN 16 HJ VA	1" -11,5 NPT	1.5/16" -12 UN	36
GE HN 16 HJ 12 VA	1" -11,5 NPT	1.1/16" -12 UN	36
GE HN 16 HJ 20 VA	1" -11,5 NPT	1.5/8" -12 UN	46
GE HN 20 HJ 16 VA	1.1/4" -11,5 NPT	1.5/16" -12 UN	46
GE HN 20 HJ VA	1.1/4" -11,5 NPT	1.5/8" -12 UN	46
GE HN 20 HJ 24 VA	1.1/4" -11,5 NPT	1.7/8" -12 UN	50
GE HN 24 HJ 20 VA	1.1/2" -11,5 NPT	1.5/8" -12 UN	50
GE HN 24 HJ VA	1.1/2" -11,5 NPT	1.7/8" -12 UN	50

SW = uzgriežņu atslēgas platums

Izstrādājumu varianti

GE HN HJ leskrūvējama iemava, Tērauds