

Īpašības

Izmantošana Dzesēšanas un smērvielu vadi metāla griešanas apstrādei.

Modelis Tērauda nesošā vītne ar PVC iekšējo šļūteni abpusēja ieskrūvējamā tapa no tērauda ar niķeli pārklāta virsma

Īpašības Pilnīgs hermētiskums ar roku iespējams salocīt gandrīz jebkādā formā noturīgs izturīgs pret eļļām, smērvielām utt.

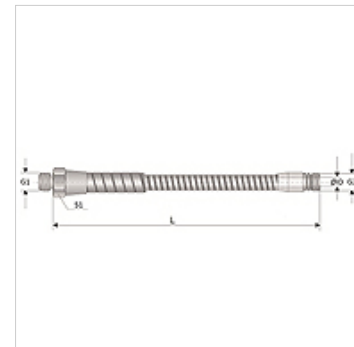

Pasūtījuma norādes

Citi izmēri pēc pieprasījuma

Izstrādājums

Apzīmējums	G1	G2	ID (mm)	S1 (mm)	Nominālais garums (+/-5 mm)
UPG G1/8-250	R 1/8"	R 1/8"	8,0	15,0	250
UPG G1/8-320	R 1/8"	R 1/8"	8,0	15,0	320
UPG G1/8-400	R 1/8"	R 1/8"	8,0	15,0	400
UPG G1/8-500	R 1/8"	R 1/8"	8,0	15,0	500
UPG G1/4-200	R 1/4"	R 1/4"	10,0	19,0	200
UPG G1/4-250	R 1/4"	R 1/4"	10,0	19,0	250
UPG G1/4-320	R 1/4"	R 1/4"	10,0	19,0	320
UPG G1/4-400	R 1/4"	R 1/4"	10,0	19,0	400
UPG G1/4-500	R 1/4"	R 1/4"	10,0	19,0	500
UPG G1/4-630	R 1/4"	R 1/4"	10,0	19,0	630
UPG G1/4-800	R 1/4"	R 1/4"	10,0	19,0	800
UPG G3/8-200	R 3/8"	R 3/8"	10,0	24,0	200
UPG G3/8-320	R 3/8"	R 3/8"	10,0	24,0	320
UPG G3/8-400	R 3/8"	R 3/8"	10,0	24,0	400
UPG G3/8-500	R 3/8"	R 3/8"	10,0	24,0	500
UPG G3/8-630	R 3/8"	R 3/8"	10,0	24,0	630
UPG G3/8-800	R 3/8"	R 3/8"	10,0	24,0	800
UPG G1/2-500	R 1/2"	R 1/2"	10,0	27,0	500
UPG G1/2-630	R 1/2"	R 1/2"	10,0	27,0	630
UPG G1/2-800	R 1/2"	R 1/2"	10,0	27,0	800