

### Īpašības

**Materiāls** NBR

**Izmantošana** elektromotoriem ar konstrukciju IM B35

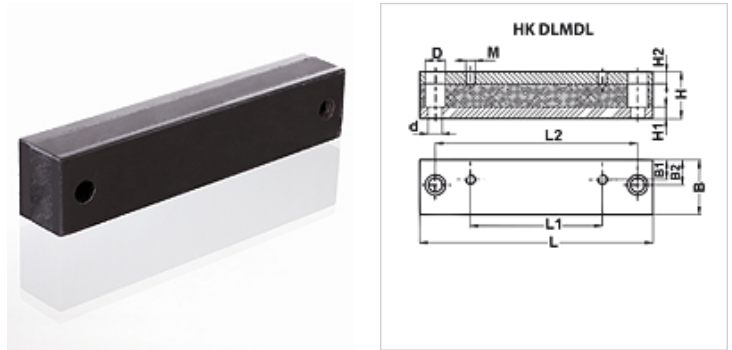

### Apraksts

trokšņa mazināšanai un vibrāciju slāpēšanai

Amortizējoša dabīgā gumija, vulkanizēta ar tērauda slīdēm

Starp konstrukciju un pamatni nav neviena metāla savienojuma

### Izstrādājums

Apzīmējums	IEC dzinēja tipizmers	B (mm)	B1 (mm)	B2 (mm)	D (mm)	d (mm)	H (mm)	H1 (mm)	H2 (mm)	L (mm)	L1 (mm)	L2 (mm)	M	Svars (kg)
HK DLMDL 90L	90L	50,00	22,0	25,0	20,0	14,00	40,0	8,00	12	240,0	125,0	205,0	M8	2,10
HK DLMDL 100L	100L	50,00	24,0	25,0	20,0	14,00	40,0	8,00	12	240,0	140,0	205,0	M10	2,25
HK DLMDL 112M	112 M	50,00	20,0	25,0	20,0	14,00	40,0	8,00	12	240,0	140,0	205,0	M10	2,30
HK DLMDL 132S	132S	50,00	20,0	25,0	20,0	14,00	45,0	8,00	12	285,0	140,0	245,0	M10	2,42
HK DLMDL 132M	132M	50,00	20,0	25,0	20,0	14,00	45,0	8,00	12	285,0	178,0	245,0	M10	2,42
HK DLMDL 160M	160M	70,00	28,0	35,0	26,0	18,00	60,0	15,00	15	340,0	210,0	300,0	M12	7,50
HK DLMDL 160L	160L	70,00	28,0	35,0	26,0	18,00	60,0	15,00	15	416,0	254,0	370,0	M12	7,50
HK DLMDL 180M	180M	70,00	35,0	35,0	26,0	18,00	60,0	15,00	15	416,0	241,0	370,0	M12	8,00
HK DLMDL 180L	180L	70,00	35,0	35,0	26,0	18,00	60,0	15,00	15	446,0	279,0	400,0	M12	8,00
HK DLMDL 200L	200L	70,00	35,0	35,0	32,0	22,00	60,0	15,00	15	496,0	305,0	430,0	M16	8,55