

Īpašības

Modelis	Stieņa uznavas gredzens
Ekspluatācijas spiediens	līdz 400 bar
Slīdes ātrums max.	0,5 m/s
Temperatūra min.	-30 °C
Temperatūra max.	80 °C
Darba vides	Minerāleļļas
Montāža	atvērtajās rievās B Slēgtajās rievās atklātās uzstādīšanas telpās
Materiāls	PUR
Izmantošana	Hidrauliskā sistēma

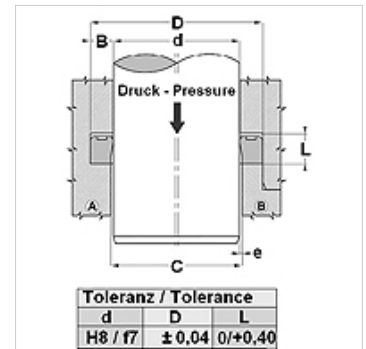

Druck bar	Spaltmaß / Clearance			
	e (mm)			
	TS-TS...L		TS...-AI-TS...-LA	
	d<60mm	d>60mm	d<60mm	d>60mm
50	<0,40	<0,50	<0,60	<0,80
100	<0,30	<0,40	<0,60	<0,80
200	<0,20	<0,30	<0,40	<0,60
300	<0,15	<0,20	<0,30	<0,40
400	<0,10	<0,15	<0,20	<0,30
500			<0,10	<0,15



Apraksts

augsta nodilumizturība
Ļoti laba blīvējuma efektivitāte zemā spiedienā.
Straujas slodzes maiņas.

Pasūtījuma norādes

Blīvējumus, kuru diametrs ir no 20 līdz 510 mm, varam izgatavot īsā termiņā.

Izstrādājums

Apzīmējums	d (mm)	D (mm)	L (mm)
TS 12 18	12	18,0	5,0
TS 16 22	16	22,0	4,5
TS 16 24-1	16	24,0	7,0
TS 18 25	18	25,0	5,7
TS 20 25	20	25,0	3,5
TS 20 25-1	20	25,0	4,5
TS 20 26	20	26,0	6,0
TS 20 27	20	27,0	6,5
TS 20 30	20	30,0	8,0
TS 20 30-1	20	30,0	9,0
TS 20 30-2	20	30,0	11,0
TS 21 27	24	27,0	5,0
TS 22 28	22	28,0	5,0
TS 22 30	22	30,0	8,0
TS 22 32-1	22	32,0	9,0
TS 24 30	24	30,0	5,0
TS 25 32	25	32,0	5,0
TS 25 35	25	35,0	6,0
TS 25 35-2	25	35,0	10,0
TS 25 35-5	25	35,0	11,0
TS 25 36	25	36,0	6,0
TS 30 38	30	38,0	9,0
TS 30 40-1	30	40,0	8,0
TS 32 40	32	40,0	9,0
TS 32 42-1	32	42,0	9,0
TS 32 42-2	32	42,0	11,0
TS 35 43-1	35	43,0	9,0
TS 35 45	35	45,0	8,0
TS 36 44	36	44,0	9,0
TS 38 45	38	45,0	7,0
TS 40 50	40	50,0	7,0
TS 42 53	42	53,0	10,0
TS 45 53-1	45	53,0	7,0
TS 45 53	45	53,0	9,0
TS 46 54	46	54,0	9,0
TS 50 62	50	62,0	11,0
TS 56 66-1	56	66,0	7,5
TS 56 66	56	66,0	11,0



Izstrādājums

Apzīmējums	d (mm)	D (mm)	L (mm)
TS 60 70-3	60	70,0	13,0
TS 61 69	61	69,0	9,0
TS 63 71	63	70,0	9,0
TS 66 80	66	80,0	11,0
TS 68 76	68	76,0	9,0
TS 70 80	70	80,0	8,0
TS 70 80-2	70	80,0	13,0
TS 72 78	72	78,0	7,0
TS 76 84	76	84,0	9,0
TS 85 97	85	97,0	9,5
TS 88 96	88	96,0	9,0
TS 90 96	90	96,0	5,5
TS 90 100	90	100,0	7,5
TS 91 99	91	99,0	9,0
TS 107 115	107	115,0	9,0
TS 126 134	126	134,0	9,0
TS 145 153	145	153,0	9,0
TS 147 155	147	155,0	11,0
TS 175 183	175	183,5	9,0
TS 221 229	221	229,5	13,0